

Cyclone Rake **SPS-10**



OWNER'S MANUAL

SAFETY

THE CYCLONE RAKE® SPS-10 IS A POWERFUL MACHINE.

DO NOT attempt to operate until you have read and completely understand this safety section.

IMPORTANT

- **THE SPS-10 ENGINE IS NOT SHIPPED WITH OIL.** Please read all instructions and fill the engine with oil before starting.
- **NEVER START THE ENGINE UNLESS IT IS BOLTED FIRMLY TO THE CHASSIS.**
The wheels on the engine unit are for ease of storage **ONLY**. They will **NOT SUPPORT THE ENGINE** while running and you risk a serious overturning or a roll-away accident.
- **DO NOT USE THE ENGINE UNIT AS A STAND-ALONE VACUUM. IT MUST ALWAYS BE BOLTED TO THE CHASSIS BEFORE OPERATING.** You risk serious injury from a roll-away accident.
- **DO NOT MAKE DESIGN MODIFICATIONS TO THIS EQUIPMENT** or any of its accessories or upgrades. You could risk serious personal injury or damage to the equipment.
- **NEVER CHANGE HOSES UNLESS THE ENGINE IS STOPPED.** You can be seriously injured by rotating machinery, high vacuum forces or flying debris.
- **NEVER OPERATE UNLESS ALL HOSES AND AIR FLOW CONNECTIONS ARE FIRMLY LATCHED IN PLACE.**
- **NEVER CLEAR JAMS UNLESS THE ENGINE IS STOPPED.**
- **ALWAYS WEAR EYE PROTECTION** when you operate the Cyclone Rake SPS-10
- **NEVER OPEN THE COLLECTOR CAP WHEN THE ENGINE IS RUNNING, EVEN TO CHECK CONTENTS.** You risk serious injury. **ALWAYS STOP** the engine first.
- **ALWAYS KEEP THE ENGINE/BLOWER UNIT FREE FROM ALL ORGANIC MATERIAL BUILD UP.** Clean this area after every use.
- **DO NOT ALLOW CHILDREN TO OPERATE THIS EQUIPMENT.**
- **KEEP CHILDREN AND PETS AWAY.** They can be seriously injured by this machinery.
- **ORGANIC LAWN DEBRIS ONLY! DO NOT ATTEMPT TO VACUUM METAL, GLASS, TRASH, STONES, SAND, CARPENTRY CUTTINGS OR ANYTHING ELSE EXCEPT NATURAL LAWN DEBRIS.** You risk damage to the Cyclone Rake and serious personal injury.
- **STOP THE ENGINE AND REMOVE THE SPARK PLUG WIRE** before performing any service or adjustment functions.
- **DO NOT CHANGE ENGINE OR GOVERNOR SETTINGS.** They are there for your safety.
- **CHECK ALL BOLTS AND FITTINGS FOR TIGHTNESS** at frequent intervals. If you sense any abnormal vibration, **IMMEDIATELY STOP** the equipment and check thoroughly.
- **USE ONLY THE NYLON LOCK NUTS AND FASTENERS** supplied with the Cyclone Rake for product assembly. **DO NOT REPLACE EXCEPT WITH IDENTICAL PARTS.**
- **DO NOT FILL FUEL TANK INDOORS. DO NOT SMOKE WHILE FUELING. WIPE UP ANY FUEL SPILLS IMMEDIATELY.**



CONTENTS

| | |
|--|----|
| SAFETY | 1 |
| CHAPTER 1: INTRODUCTION & UNPACKING | 2 |
| Contents of the Manual | 2 |
| Getting Started | 2 |
| The Cyclone SPS-10 Main Components..... | 3 |
| CHAPTER 2: ASSEMBLING YOUR CYCLONE RAKE SPS-10 | 4 |
| Assemble the Chassis & Handlebars | 4 |
| Install the Engine/Blower Unit | 7 |
| Assemble & Connect the Collector Cap to the Handlebar | 8 |
| Assemble the Collector Insert | 9 |
| Assemble the Power Vacuum Pickup | 10 |
| CHAPTER 3: USING THE CYCLONE RAKE SPS-10 | 11 |
| Blower Mode Setup | 11 |
| Collection Mode Setup | 12 |
| Using Paper Collection Bags | 12 |
| Using the Fabric Collection Bag | 13 |
| Attaching the Power Vacuum Pickup | 14 |
| Using theXR950-PRO Engine | 15 |
| CHAPTER 4: WARRANTY & MAINTENANCE | 16 |
| Protecting Your Investment (Warranty Explained) | 16 |
| Engine Maintenance | 16 |
| General Maintenance | 18 |
| Storing Your Cyclone Rake SPS-10 | 18 |
| CHAPTER 5: OPERATING TIPS & TROUBLESHOOTING GUIDE | 19 |
| Operating the Cyclone Rake SPS-10 | 19 |
| Troubleshooting Guide | 20 |
| CHAPTER 6: SERVICE PARTS | 22 |
| MANUFACTURER'S WARRANTY | 29 |
| ASSEMBLING YOUR CYCLONE RAKE SPS-10 VIDEOS | 30 |
| SERVICE NOTES | 31 |

CHAPTER 1

INTRODUCTION & UNPACKING

Congratulations on your purchase of the Cyclone Rake SPS-10!

We believe you'll find this machine to be the best small property solution for clearing leaves off your property. A blower and collector unit all in one, the SPS-10 makes debris cleanup a breeze. Made from high-quality parts that are durable and made to last, you'll find the right maintenance and use will give you years of reliable service.

CONTENTS OF THIS MANUAL

The Owner's Manual covers the assembly, operation, and maintenance your Cyclone Rake SPS-10. Please keep this manual somewhere safe where you can easily access it as you will need to follow the instructions in the order presented for optimal performance. The manual also includes all the parts included in the boxes and the tools you will need for assembling.

EASY TO ACCESS ASSEMBLY VIDEOS

To help in assembling the SPS-10, we've included brief and easy-to-follow videos that can be viewed simply by scanning the QR Code with your smartphone. If you don't have a smartphone, don't worry. All our assembly videos are in one spot on our website. We recommend watching these videos first, so you have a good understanding of the machine and how it works before putting it together.

<https://www.cyclonerake.com/sps-10-assembly-videos/>

USING A QR CODE

Whenever you see a QR code like this one, just scan them with your mobile phone or tablet, and immediately watch a video related to that section of your owner's manual. These codes and the videos will demonstrate the assembly of your new Cyclone Rake SPS-10. Download a QR code reader from the Apple App store, Google Play, or scan them with your phone camera to open a web link. Try them out! We think you'll find them helpful, and we're confident they'll make your ownership experience more enjoyable.



GETTING STARTED

Your Cyclone Rake® SPS-10 is shipped in 3 boxes.

To get started, first identify your 3 boxes, which have these box names:

- **SPS-10 Box:** This contains the Owner's Manual, Chassis, Lower and Upper Handlebars, the Bag Platform, the Collector Cap, Blower Inlet Guard, SPS-10 Hose, Wheels, Corrugated Collector Box, Fabric Collector Bag, and Bag Caddie as well as all of the hardware needed for assembly.

ASSEMBLY NOTE: Before starting to assemble, please unpack the contents of the SPS-10 Box to familiarize yourself with all assembly components.

- **Engine/Blower Unit Box:** This contains the power system to drive the operation of your SPS-10.
- **Power Vacuum Pickup Box:** This contains the extension vacuum hose and wand to allow you to collect materials from hard to reach areas or simply vacuum piles of leaves.

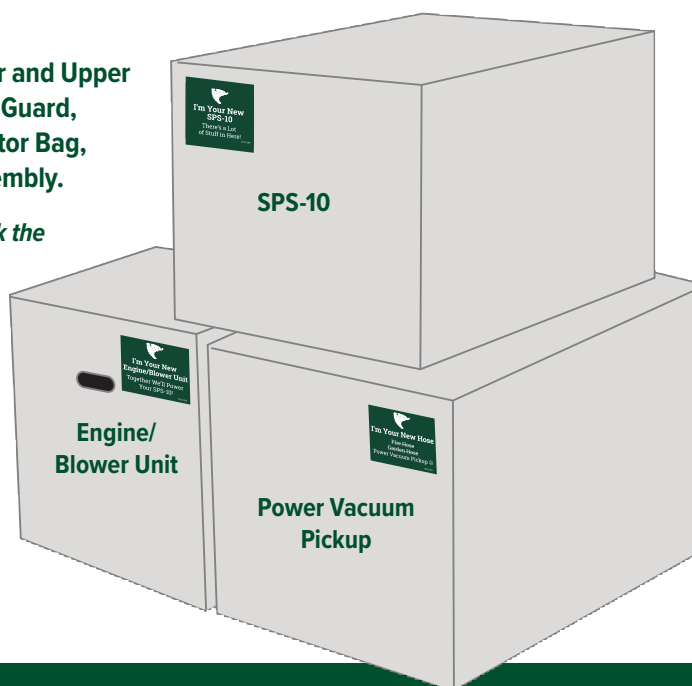

THE CYCLONE RAKE SPS-10 MAIN COMPONENTS

BLOWER MODE

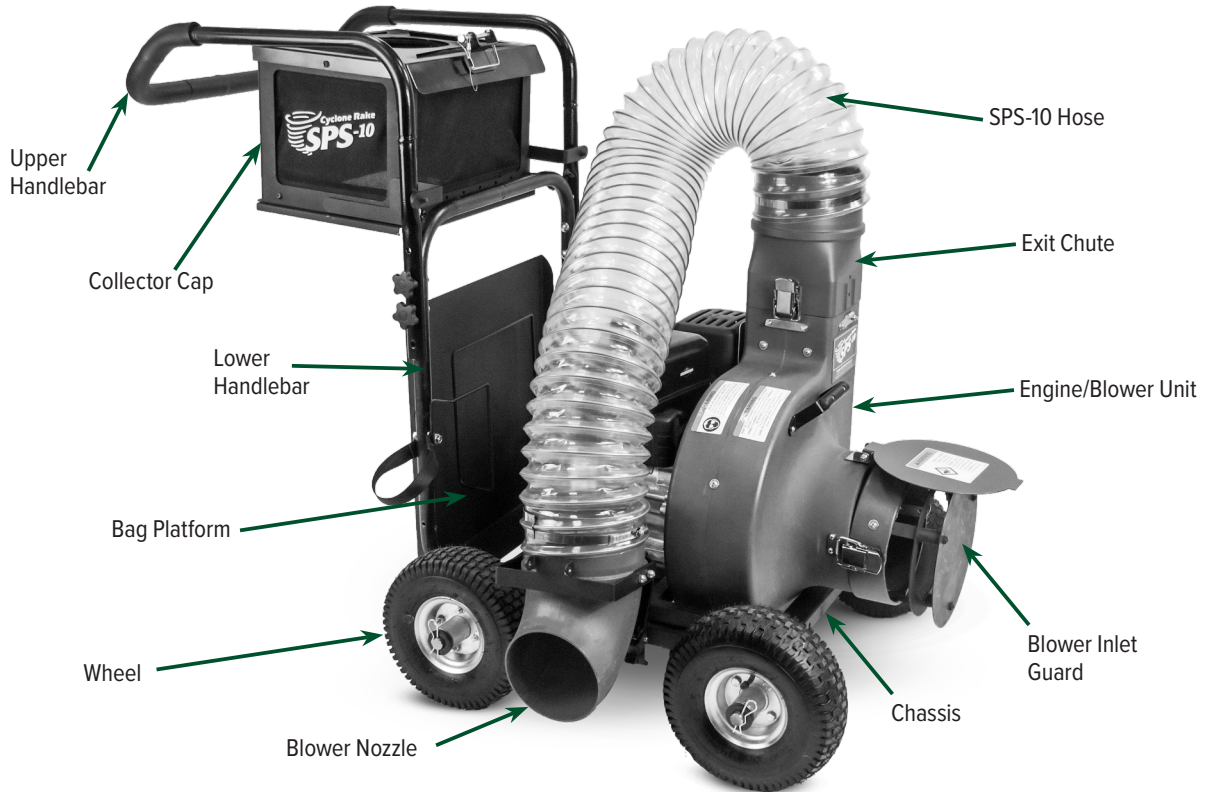

COLLECTION MODE

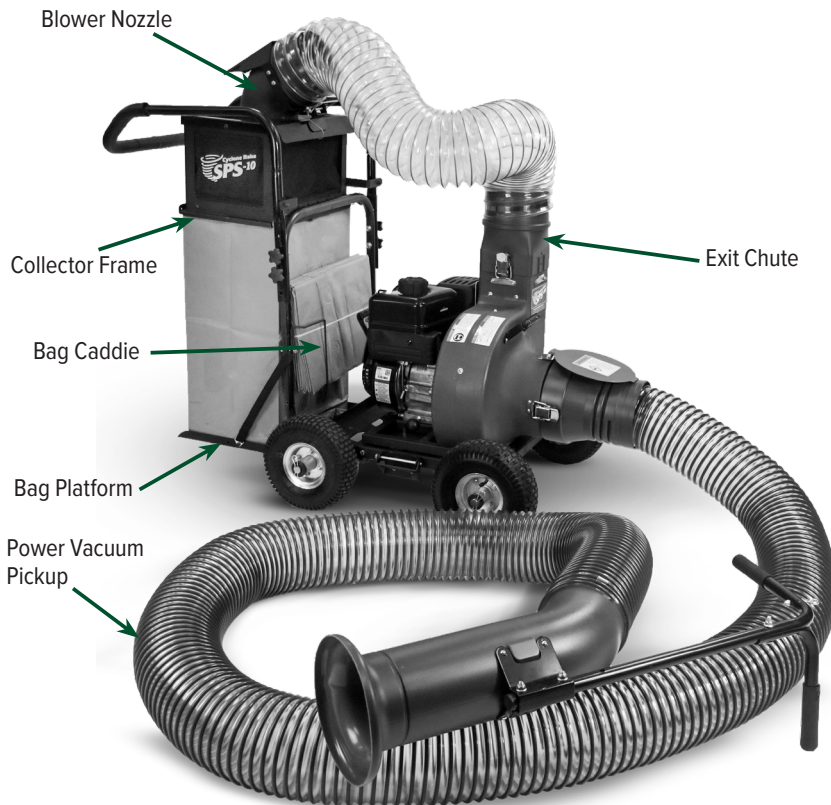

Shown with Fabric Collector Bag



CHAPTER 2

ASSEMBLING THE SPS-10

All the parts you need to assemble the will be in the SPS-10 Box.
 All the harware you'll need will be packaged in a separate box that can be found inside the SPS-10 Hose.

ASSEMBLE THE CHASSIS & HANDLEBARS

ATTACH THE LOWER HANDLEBAR TO THE CHASSIS

- PARTS YOU'LL NEED**
- Chassis
 - Lower Handlebar

- HARDWARE YOU'LL NEED IN THE BAG MARKED:**
12-01-088 HANDLEBAR TO CHASSIS HARDWARE KIT
- (4) 5/16-18 x 1.5" Bolts
 - (4) 5/16-18 Nylon Lock Nuts

- TOOLS YOU'LL NEED:**
- (2) 1/2" Box wrenches or sockets

1. **(Fig. 1)** Slide the end of the Lower Handlebar into the openings in the rear of the Chassis.
2. **(Fig. 2)** Align the holes in the Chassis and the Lower Handlebar. Then attach the Handlebar to the Chassis using four 5/16" bolts and nylon lock nuts. One on the side and one at the top of each side. Secure with the 1/2" wrenches.

TIP: *Once the Lower Handle bar is inserted, it may help to flip the chassis to have better access to the bolts and lock nuts.*

SAFETY NOTE:

Single cylinder engines always create high vibration. For safety, the Cyclone Rake® SPS-10 makes extensive use of "shake-proof" nylon lock nuts. Always use them where indicated. Do not substitute ordinary nuts. If you lose any, you can buy them at any hardware store.



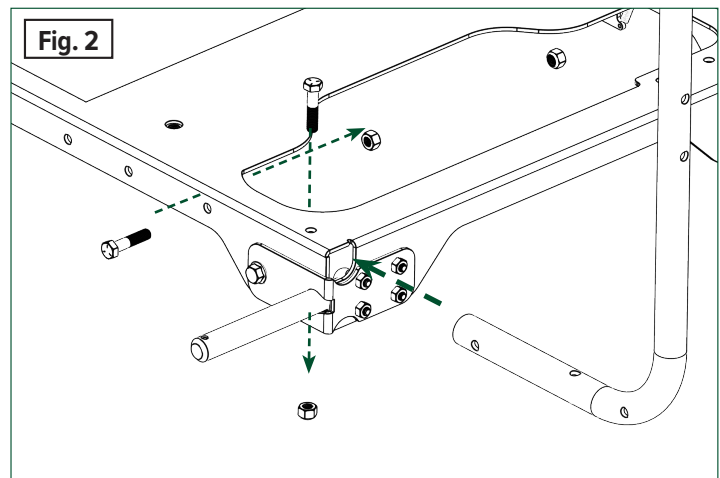
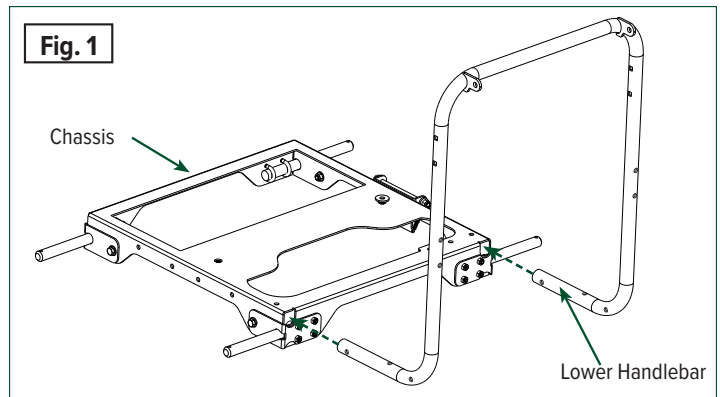

ATTACH THE WHEELS



PARTS YOU'LL NEED

- (4) Wheels

HARDWARE YOU'LL NEED IN THE BAG MARKED: 12-01-086 WHEEL HARDWARE KIT

- (12) Washers
- (4) Cotter pins

TOOLS YOU'LL NEED:

- None

1. **(Fig. 1)** Slide 2 washers onto an axle followed by a wheel with the valve stem facing out, then slide 1 washer onto axle.
2. **(Fig. 2)** Secure with Cotter Pin.
3. Repeat steps 1 and 2 for the remaining wheels.

NOTE: *Recommended tire inflation: 25 psi*

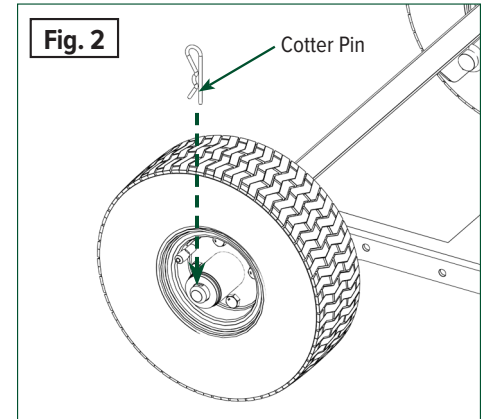
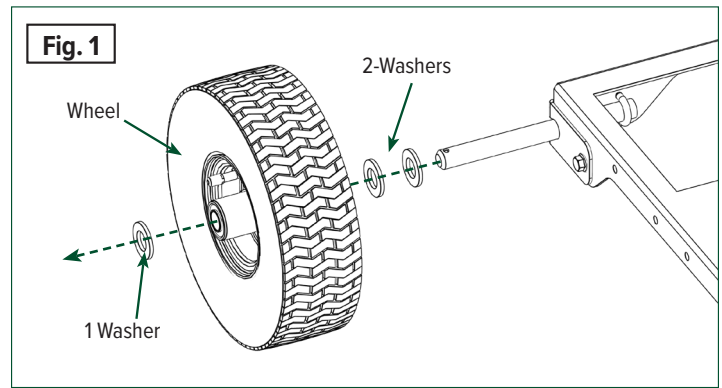

ATTACH THE BAG PLATFORM TO THE LOWER HANDLEBAR



PARTS YOU'LL NEED

- Bag Platform

HARDWARE YOU'LL NEED IN THE BAG MARKED: 12-01-092 PLATFORM HARDWARE KIT

- (2) Clevis pins
- (2) Cotter pins

TOOLS YOU'LL NEED:

- None

1. **(Fig. 1)** At the rear of the Chassis, insert the Bag Platform between the Lower Handlebar tubes. Locate and align the pin holes. From the inside of the Bag Platform, insert a Clevis Pin on each side.

INSTALLATION NOTE:

To make installation easier use a piece of cardboard from package to help keep platform level during installation (approx. 3.5" off ground).

2. **(Fig. 2)** Secure both Clevis Pins with a Cotter Pin on the outside of the handlebar tube.

NOTE: *The Platform may have some play left to right once installed. This is normal.*

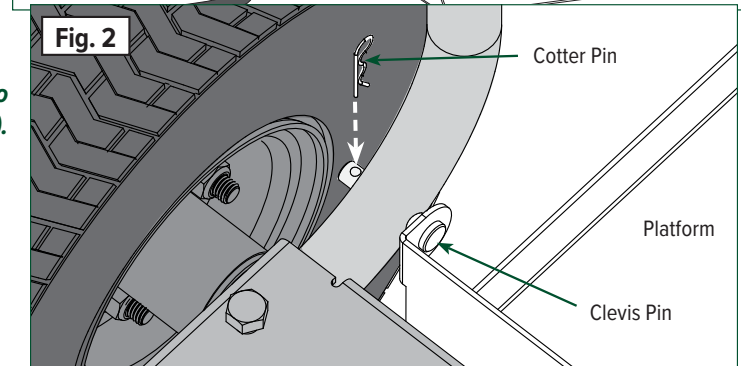
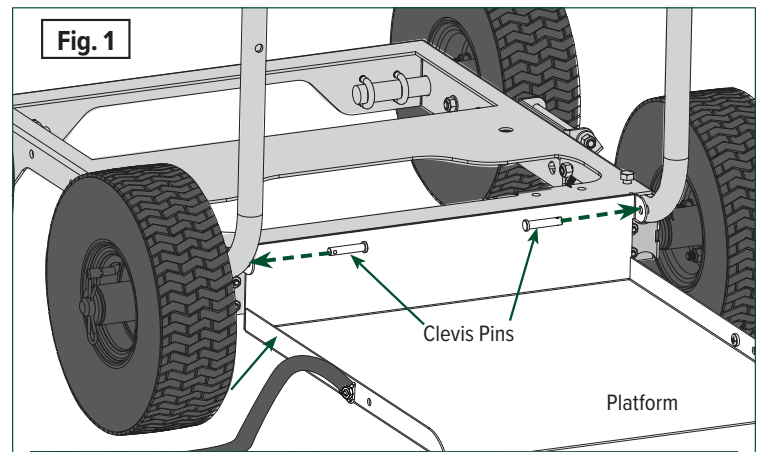

ATTACH THE PLATFORM LOCK & BAG CADDIE TO THE LOWER HANDLEBAR



PARTS YOU'LL NEED

- Platform Lock (located in the Hardware Box)
- Bag Caddie

HARDWARE YOU'LL NEED IN THE BAG MARKED:

12-01-091 HANDLEBAR LOCK BRACKET KIT

- (2) 5/16-18 x 1.75" Hex bolts
- (2) 5/16-18 x 1.5" Hex bolts
- (4) 5/16-18 Nylon lock nuts

TOOLS YOU'LL NEED:

- (2) 1/2" Box wrenches or sockets

1. **(Fig. 1)** At the back, right side of the lower handlebar, insert (2) 5/16 – 1.75" Hex Bolts through Platform Lock and Handlebar.
2. **(Fig. 2)** On the left side of the Lower Handlebar install the Bag Caddie onto the hex bolts. Starting on the right side, attach the Platform Strap onto the lower 1.75" Hex bolt and secure the strap and caddie with 2 nylon lock nuts. Then on the left side attach the Platform Strap onto the lower 1.5" Hex bolt and secure the strap and caddie with 2 nylon lock nuts.

NOTE: *The Platform Straps should be pulled up through the inside of the handlebars.*

4. Adjust the length of the Platform Straps so the Platform is parallel to the ground.
5. **(Fig. 3)** Lift the platform, pull out the Platform Lock pin and secure the Platform in the stowed position.

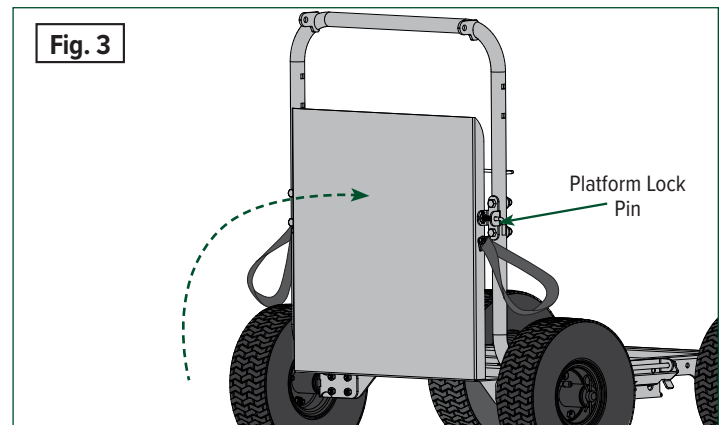
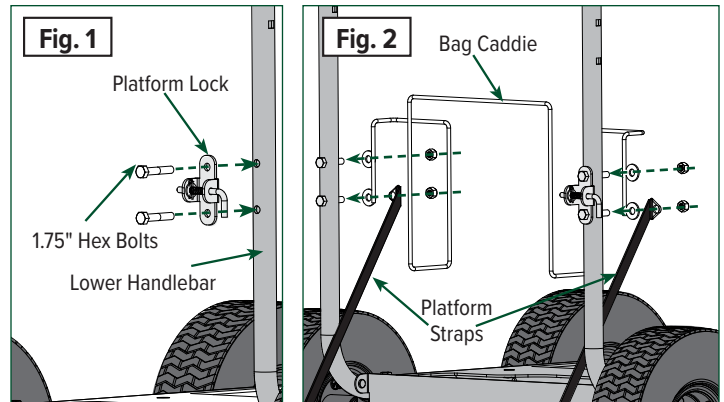

ATTACH THE UPPER HANDLEBAR



PARTS YOU'LL NEED

- Chassis
- Upper Handlebar

HARDWARE YOU'LL NEED IN THE BAG MARKED:

12-01-087 HANDLEBAR HARDWARE KIT

- (4) 5/16-18 x 2" Carriage bolts
- (4) Rubber washers
- (4) Knobs

TOOLS YOU'LL NEED:

- None

1. **(Fig. 1)** Slide Upper Handlebar downward over Lower Handlebar.

NOTE: *There are 3 height settings. Find the one that is most comfortable for you.*

2. **(Fig. 2)** Attach both handlebars by installing four 5/16" carriage bolts through the square holes in the Lower Handlebar then through the holes in the Upper Handlebar.
3. Secure with the Rubber Washers and Knobs making sure to tighten all four knobs until handlebars are fully secure.

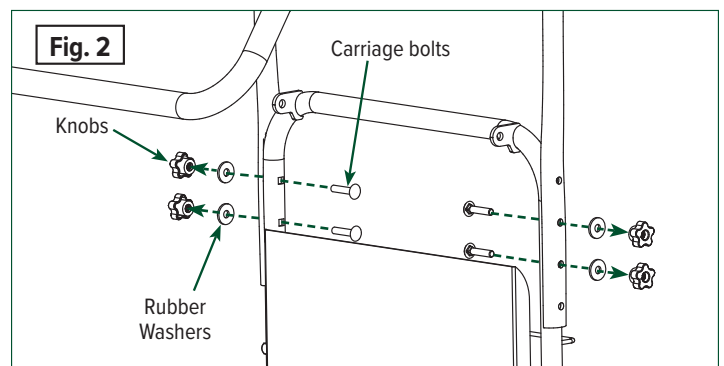
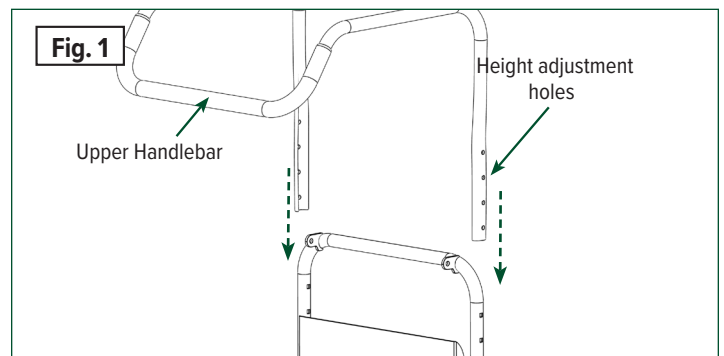

INSTALL THE ENGINE/BLOWER UNIT



The **SPS-10 Engine/Blower Unit** is on its own chassis with wheels. It's located in the box labeled **Engine/Blower Unit**.

- (Fig. 1)** Remove the Engine/Blower Unit using the handles on each side and position it on the chassis with the blower inlet facing away from the handlebars.

NOTE: *Locate the two engine clamp knobs and rubber washers Engine Clamp Knob Kit in the Hardware Box.*

- (Fig. 2)** Line up the mounting brackets on both sides of the Engine/Blower Unit over the threaded holes in the Chassis. Install one rubber washer on each clamp knob then securely clamp the engine to the cart by screwing the engine clamp knobs through the holes.

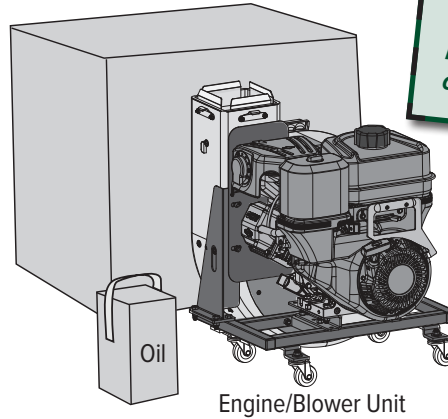

CAUTION:
The Engine/Blower Unit is heavy. You may need assistance removing it from the box and lining it up on the chassis.

WARNING:
Do not start the engine now! The engine contains no oil or gasoline and you have not completed the assembly of your Cyclone Rake SPS-10.

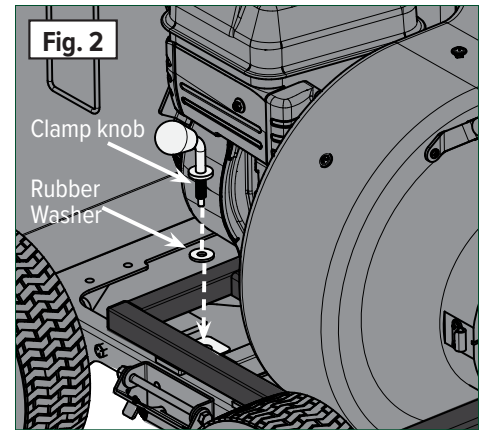
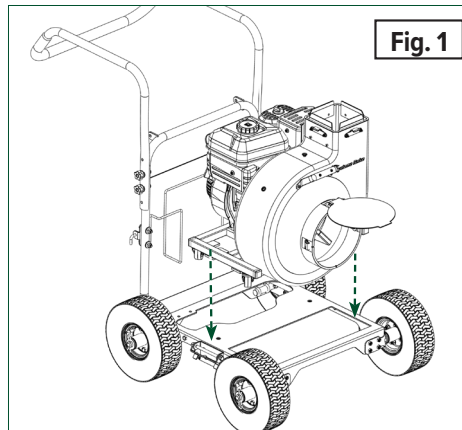

FILL THE ENGINE WITH OIL



OIL CAPACITY: XR950-PRO: 18-20 OZ.

NOTE: *The oil refill amounts are slightly lower than total oil capacity due to residual oil left in the engine during the testing process.*

IMPORTANT: *Do not use the dipstick on the butterfly plug to measure when filling the engine oil. It is hard to read when the oil is new, and you might over or under fill, resulting in engine damage. Instead, use this simple procedure:*

- (Fig. 3)** There are two **YELLOW** plastic “butterfly” plugs at the base of the engine. Remove one of the plugs and place a rag under the opening to catch any spilled oil.
- (Fig. 4)** Using a small funnel, slowly pour oil into the opening **until the oil reaches the bottom edge of the butterfly hole**. (See chart below for recommended oils.)
- Replace the butterfly plug and **tighten firmly by hand**. Do not use a wrench or pliers as you might break the plug. Wipe up any spilled oil.

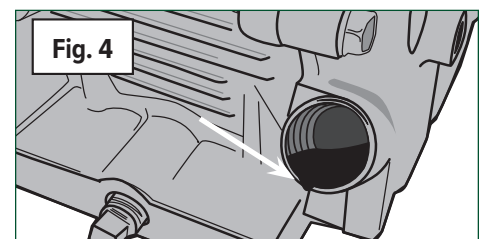
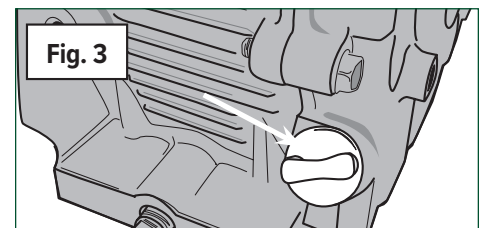

| RECOMMENDED OIL CHART | |
|---|-------------------------|
| <i>The oil should be marked A.P.I. service “SF,” “SG,” “SH,” “SJ” or higher.</i> | |
| Air Temperature | Type of Oil |
| Above 32° F | SAE 30 or SAE 10W30 oil |
| Below 32° F | SAE 5W30 oil |
| <i>If synthetic oil is preferred 5W-30 is good in all temps. SAE 10W40 is specifically not recommended.</i> | |

ASSEMBLE & CONNECT THE COLLECTOR CAP TO THE HANDLEBAR

ASSEMBLE THE COLLECTOR CAP



PARTS YOU'LL NEED

- Collector Cap

HARDWARE YOU'LL NEED IN THE BAG MARKED:

12-02-034 TOP DOCKING BRACKET ASSEMBLY

- Top Docking Bracket
- Quick Release Pin
- (2) 1/4-20 Nylon Lock Nuts

TOOLS YOU'LL NEED:

- 7/16" Open-end wrench

1. **(Fig. 1)** Insert both Top Docking Bracket studs into the two center holes in slanted flange of the Collector Cap, making sure Top Docking Bracket is facing upward as shown. Attach the Tether Wire of the Quick Release Pin onto either stud **behind the flange**. Then, secure both studs with two nylon lock nuts with the 7/16" open-end wrench **behind the flange**.
2. **(Fig. 2)** Open the Quick Release Pin and insert the pin into the Docking Bracket and secure with the other end.

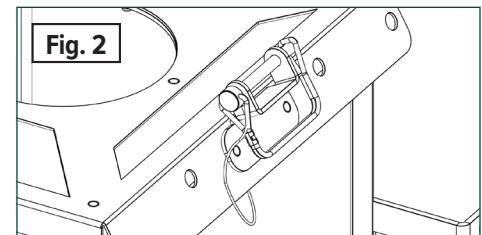
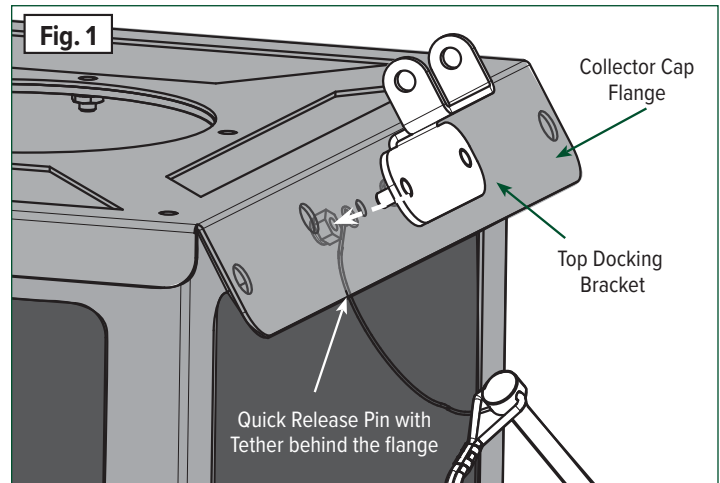

ATTACH THE COLLECTOR CAP TO THE HANDLEBAR



PARTS YOU'LL NEED

- Collector Cap

HARDWARE YOU'LL NEED IN THE BAGS MARKED:

12-01-093 COLLECTOR CAP PINS, SET OF 2

01-02-120 RRC CLAMP BRACKET AND KNOB, SET OF 2

- (2) Quick Release Pins
- (2) Clamp Brackets with Knobs & Washers

1. **(Fig. 3)** Lower the Collector Cap between the upper handlebars making sure the hinge tabs on the Collector Cap are on the front of the handle bars.
2. **(Fig.4)** Align the holes on the sides of the Collector Cap Hinge with the holes in the tabs on the Lower Handlebar. Insert a Quick Release Pin to secure.
3. Repeat on the other side.
4. **(Fig.5)** Locate outer holes in the Collector Cap Hinge of the Collector Cap. Attach knobs, washer and clamp brackets to secure to the handlebar.
5. Repeat on other side.

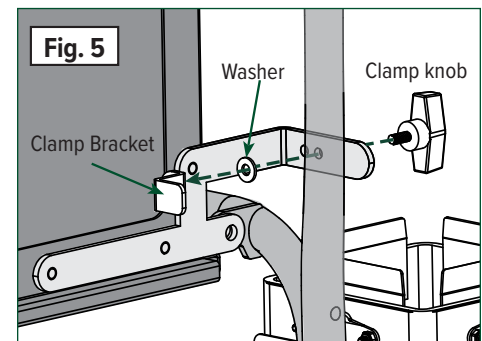
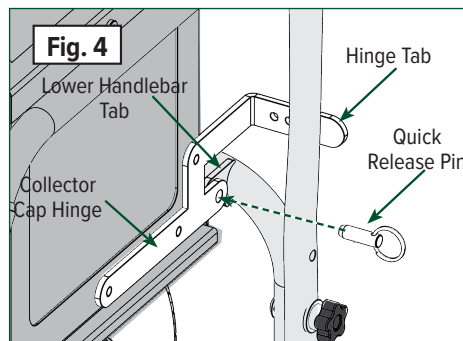
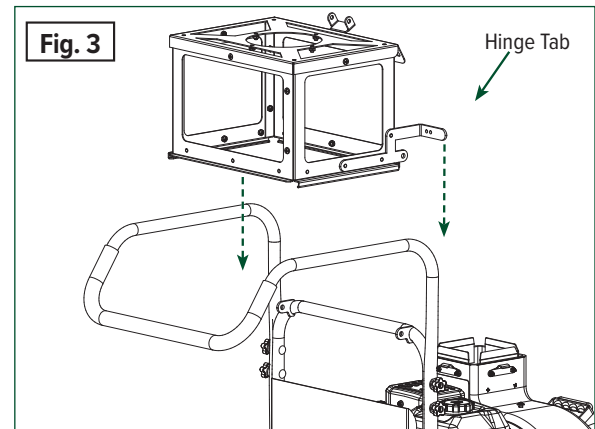

ASSEMBLE THE COLLECTOR INSERT

ATTACH THE COLLECTOR FRAME TO THE CORRUGATED INSERT



PARTS YOU'LL NEED

- (2) Collector Frames
- Corrugated Collector Insert
- Fabric Collector Bag

OTHER PARTS YOU'LL NEED IN THE BAG MARKED:

12-01-090 COLLECTOR TRAY HARDWARE KIT

- (12) 10-24 x 0.25 Panhead Philips screws
- (12) T-nuts

TOOLS YOU'LL NEEDED:

- Phillips head screwdriver

ASSEMBLE THE COLLECTOR INSERT

1. **(Fig. 1)** Slide the Frame onto the top of the Collector Insert. Align the holes in the Frame and the Corrugated Box.
2. **(Fig. 2)** Using a Phillips head screwdriver, fasten (12) Panhead Screws from the inside of the Collector Insert into (12) T-nuts on the outside of the Collector Insert.

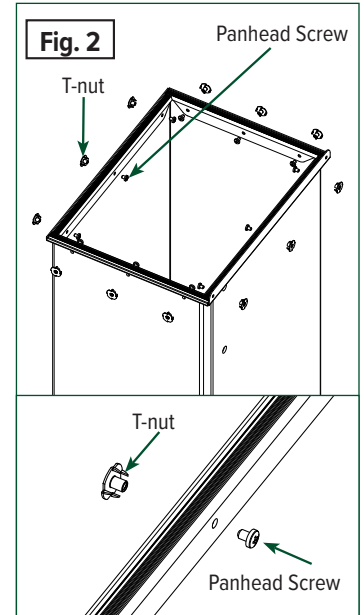
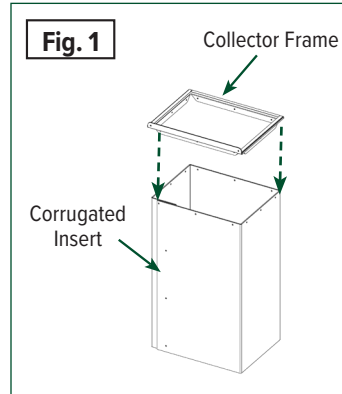

ASSEMBLE THE POWER VACUUM PICKUP

You'll be using the Power Vacuum Pickup to fill your paper bags or fabric bag with all your leaves. But, you can use it to pick up just about any other organic lawn debris. It's great for pine needles, acorns, lawn thatch and more. It's also an excellent tool for clearing out window wells, culverts, planting beds and other areas.

WARNING:

Always stop the SPS-10 engine before changing hoses. High vacuum forces and rotating machinery can cause severe personal injury. NEVER change hoses unless the engine is STOPPED.

ASSEMBLE THE HANDLES

The vacuum wand handles are shipped unattached to prevent shipping damage.

TOOLS YOU'LL NEED:

- 1/2" Wrench
- (2) 7/16" Wrenches,
- Flat blade Screwdriver or 5/16" Nut Driver
- Scissors

1. Cut the nylon cable tie that is holding the two parts of the handle.
2. **(Fig. 1 & 1a)** Slip the eye-bolt into the hole above the bend of the long handle tube, and secure with the 1/4" Cap Nut. Tighten with two 7/16" wrenches.
3. **(Fig. 2)** Slide the long handle tube into the mounting bracket attached to the wand inlet, making sure the handle grip lines up over the bent portion of the wand inlet. Line up the 2 holes nearest the end of the long handle tube with the square holes in the mounting bracket. Secure with the two included carriage bolts and nuts. Tighten with the 1/2" wrench.

NOTE: If you are under 5'6" tall, you may find it more comfortable to shorten up the wand by mounting the long handle tube through the second and third holes. Figure 2a.

4. **(Fig. 3 & 4)** Attach the side handle tube to the hole beneath the bend in the long handle tube, using the last included carriage bolt and nut.
Right handed users, the side handle tube should look like **Fig3**.
Left handed users can mount the side handle to the other side as shown in **Fig. 4**. Tighten with 1/2" wrench.

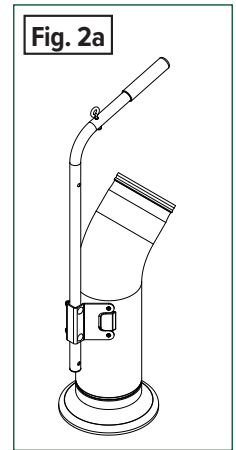
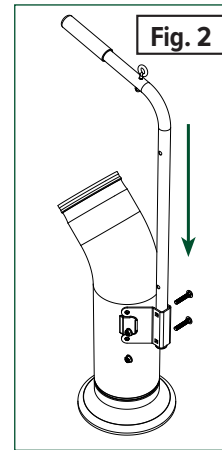
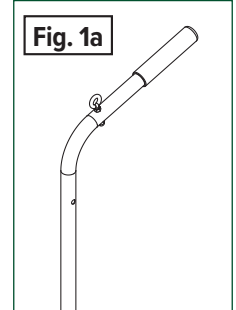
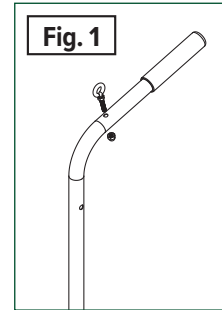

CONNECT THE HOSE TO THE VACUUM WAND

1. **(Fig. 5)** Slide the vacuum hose over the end of the molded wand 2-3". Secure with the bridge-type band clamp supplied. Use a 5/16" nut driver or flat blade screwdriver.
2. **(Fig. 6)** Be sure the "bridge" on the reverse side of the band clamp saddles neatly over the hose ribs. Also be sure the stainless steel bands are seated between the hose ribs all around.
3. Attach shoulder strap's clip to the eye-bolt on top of the handle tube.

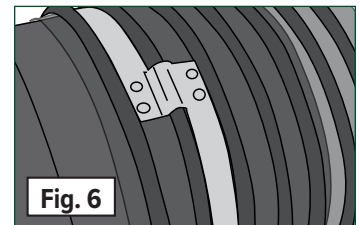
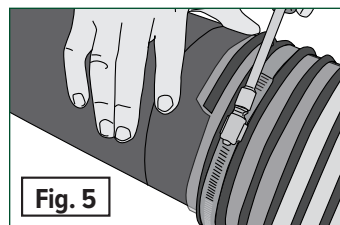
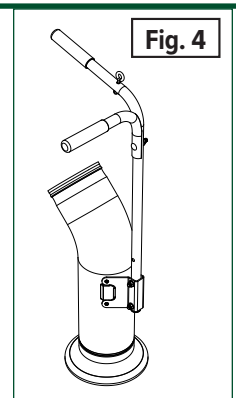
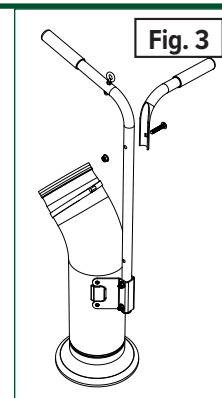

CHAPTER 3

USING THE CYCLONE RAKE SPS-10

The SPS-10 allows you to blow leaves into piles or into the woods. The SPS-10 also let's you collect those piles of debris with the Power Vacuum Pickup into either paper leaf/lawn bags for curb-side pickup or into a fabric Collector bag to dump into your compost pile or wooded area.

BLOWER MODE SET-UP



We've designed the SPS-10 to be easily maneuvered in Blower Mode. Its four wheels and comfortable handlebar let you roll forward, backward and make turns to corral all your leaves and lawn debris.

PARTS NEEDED:

- SPS-10 Hose
- Blower Inlet Guard

TOOLS YOU'LL NEED:

- None

1. **(Fig. 1)** Attach the Exit Chute end of the SPS-10 Hose to the top of the Engine/Blower Unit and secure using the Latches
2. **(Fig. 2)** Lower the Blower Nozzle behind the pin of the Nozzle Dock located on the right side of the Chassis.
3. **(Fig. 3)** Install the Blower Inlet Guard onto the front of the Blower opening and secure with the latches.

NOTE: *Make sure the Bag Platform is lifted up and in the stowed position before operating in Blower Mode.*

You're all set to start using your SPS-10 as a leaf blower

To learn how to start and stop the XR950 Engine please go to page 16.

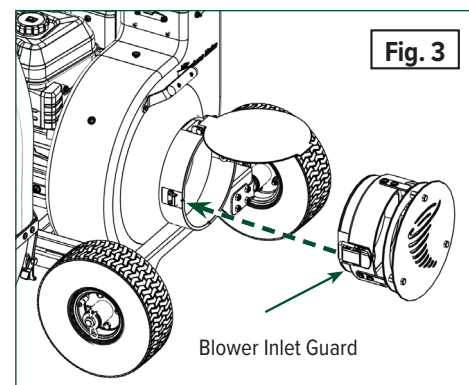
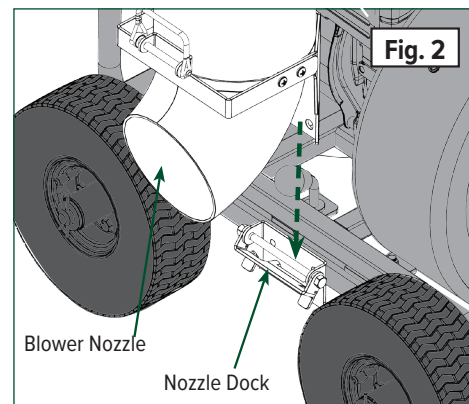
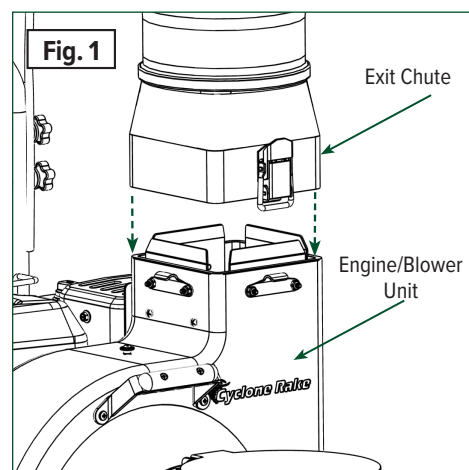

COLLECTION MODE SET-UP

When in collection mode, the SPS-10 will take the debris you've piled up and funnel it through the Blower Unit and dump it into your Paper Leaf Collection Bags for curbside pickup or, into the Fabric Collector Bag to be dumped wherever you like.

PARTS NEEDED:

- Collector Insert and Paper Leaf Bag
- OR the Fabric Collector Bag
- The Power Vacuum Pickup

ATTACH THE BLOWER NOZZLE TO THE COLLECTOR CAP



TOOLS YOU'LL NEED:

- None

1. **(Fig. 1)** Remove the Quick Release Pin at the top of the Top Docking Bracket.
2. **(Fig. 2)** Disconnect the Blower Nozzle from the Chassis by locating the thumb tabs on either side of Nozzle Dock. Flip the tabs upward while lifting Blower Nozzle to release it.
3. **(Fig. 3)** Insert the Blower Nozzle Bracket tab into the round opening at the top of the Collector Cap.
3. **(Fig. 4)** Then tilt backwards to align the Blower Nozzle Bracket pin holes with those of the Top Docking Bracket. Secure by sliding the Quick Release Pin through the pin holes.

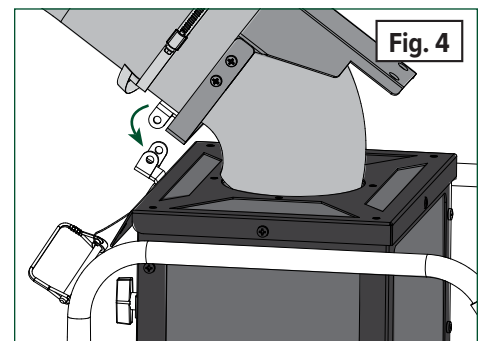
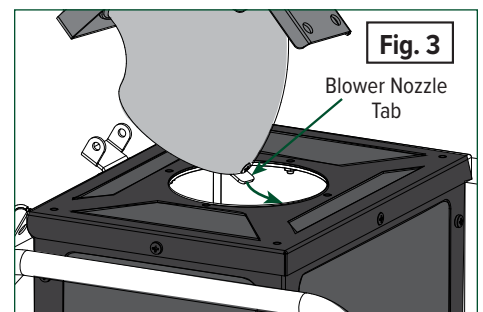
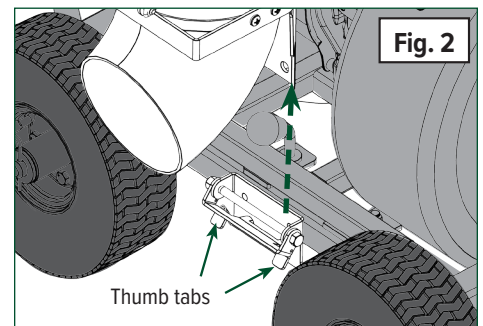
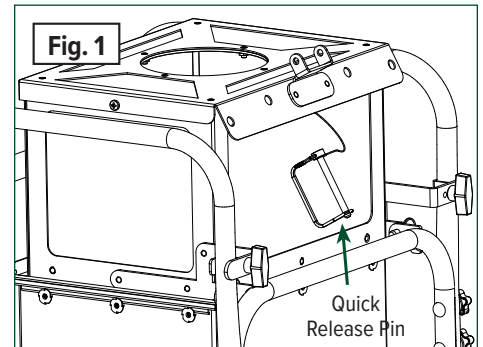



USING PAPER COLLECTION BAGS

LOWER THE PLATFORM

1. **(Fig.4)** While supporting the Platform, pull the Platform Lock Pin to release it from its stowed position. Then carefully lower the platform until it is supported by the platform straps.

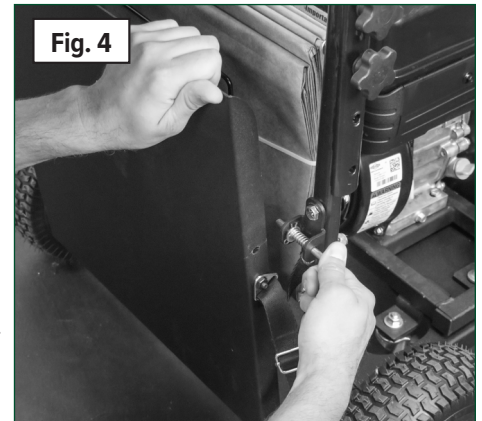

INSTALL THE COLLECTOR INSERT INTO A PAPER LEAF BAG

PARTS NEEDED:

- Corrugated Collector Insert
- Paper Leaf Bags

2. **(Fig. 5)** Flip the Corrugated Collector Insert so the metal frame is on the ground (upside down). Slide the paper bag over the Collector Insert starting on one side, then the other.
3. **(Fig. 6)** The Collector Insert should fit two-thirds to three-quarters of the bag.
4. **(Fig. 7)** Turn the Collector Insert over and push down to collapse the bottom of the paper bag.

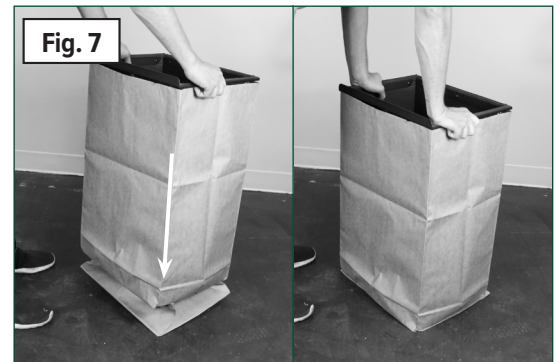
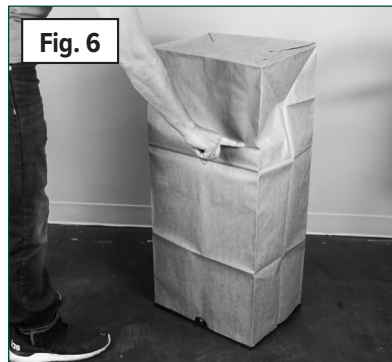
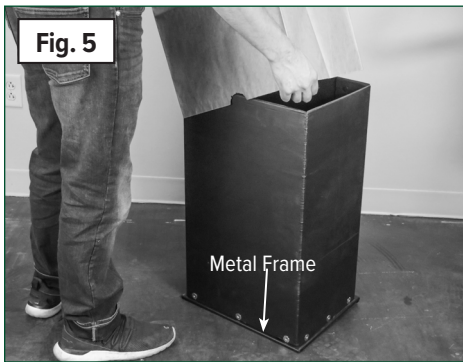

NOTE: *By using this technique, you ensure that you will have room left over at the top of the bag to close the bag for collection at the curb.*

SLIDE THE PAPER COLLECTOR BAG INTO THE CAP

1. **(Fig. 8)** Slide the Collector Bag Frame into the slots at the bottom of the Collector Cap until it's fully inserted.



USING THE FABRIC COLLECTION BAG

SLIDE THE FABRIC COLLECTOR BAG INTO THE CAP

1. **(Fig. 9)** Make sure the Bag platform is in the stowed position. Then, slide the Collector Bag Frame and Fabric Collector Bag into the slots at the bottom of the Collector Cap until it's fully inserted.



ATTACHING THE POWER VACUUM PICKUP

NOTE: Before vacuuming remove any long sticks you may find in your leaf pile. The hose may jam if you feed material longer than the hose diameter.

IMPORTANT: Stop the engine before attaching the Power Vacuum Pickup.

1. **(Fig. 1)** Remove the Blower Inlet Guard by disengaging the latches.
2. **(Fig. 2)** Attach the Power Vacuum Pickup to the Engine/Blower Unit inlet securing it with the latches. Be sure both latches are firmly locked before starting or restarting the engine.

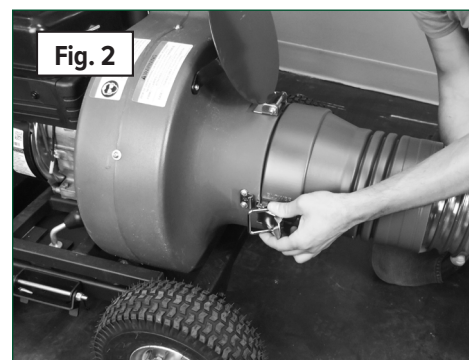
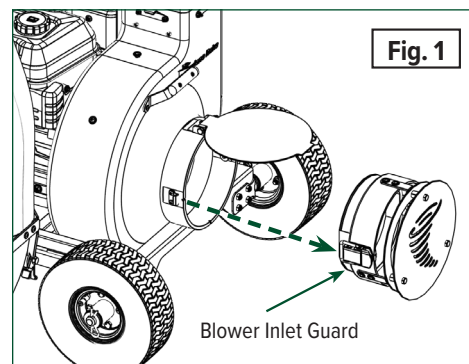

ADJUSTING THE SHOULDER STRAP LENGTH

The length of the shoulder strap can be easily adjusted to accommodate persons of various heights. Each side of the shoulder strap has a Velcro strip. You can peel back the Velcro to release it. Then re-fasten the Velcro in the most comfortable position for your use. To get the maximum (or minimum) extension length, adjust the Velcro on both sides.

You're all set to start using your SPS-10 to Collect all your debris

To learn how to start and stop the XR950 Engine please go to page 16.

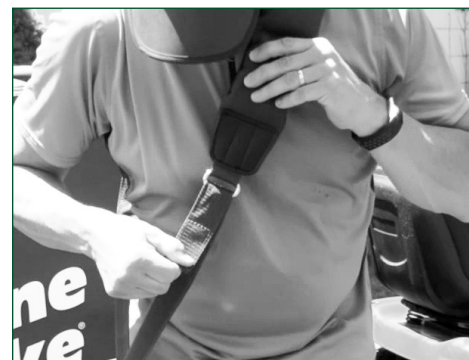

VACUUMING TIPS

- Pass the wand back and forth over the material, allowing it to enter the wand in moderate amounts.
- Keep the hose as straight as possible while vacuuming. This will increase the vacuum power and minimize the possibility of hose jams. If your hose is coiled up on the ground, straighten it out before starting. Unnecessary twists and turns can reduce power.
- Try not to overfill the bags. After some practice, you will become familiar with how much to pickup while using the SPS-10 and Power Vacuum Pickup.
- The average fill time is about 2 minutes.



REMOVING OR EMPTYING THE COLLECTOR BAGS

REMOVING THE FULL PAPER COLLECTION BAG

1. **STOP THE ENGINE.**
2. Slide the Collector Bag Frame out from the Collector Cap.
3. **(Fig. 1)** Lift the Collector Insert with the Paper bag until the paper bag is fully expanded.
4. **(Fig. 2)** Then continue to lift the Collector Insert out from the paper bag and set it aside.
5. Fold down the top of the paper bag and bring to the curb.



Now you're ready for another paper bag!

REMOVING & EMPTYING THE FABRIC COLLECTION BAG

1. Slide the Collector Bag Frame out of the Collector Cap.
2. **(Fig. 3)** Use the handles to safely dump your debris anywhere you want.

Now you're ready to collect another load!



USING THE B&S XR950-PRO ENGINE

Be sure the engine has sufficient oil before starting. Be sure the fuel tank has only **clean, fresh, unleaded regular gasoline** and that the gas cap is firmly secured to prevent spillage. **(We highly recommend adding fuel stabilizer to every tank of gas.)** Make sure to wipe up any gasoline spills before starting.

IMPORTANT: Always add fuel stabilizer per Briggs & Stratton's instructions. This is available at any hardware store or in our Engine Maintenance Kit. See the Warranty And Maintenance section for further details or refer to your Briggs & Stratton® Operating and Maintenance Manual.

WARNING:

Never start engine until the Cyclone Rake SPS-10 is completely assembled, the engine unit is firmly bolted to the chassis, and all hoses and couplings are in place.



STARTING XR950-PRO ENGINE

1. **(Fig. 1)** Push the black fuel lever on the front of the engine to the **"ON"** position.
2. **(Fig. 1)** Slide the throttle control lever **all the way to the left (rabbit)** for full throttle.
3. **(Fig. 2)** Move the **gray choke lever to the left, or full choke** position. Grasp the starter cord and pull slowly until you feel resistance. **Then pull rapidly.**
4. As the engine warms up, **move the choke lever right to the no choke** position.
5. The engine should always run at full throttle during use.

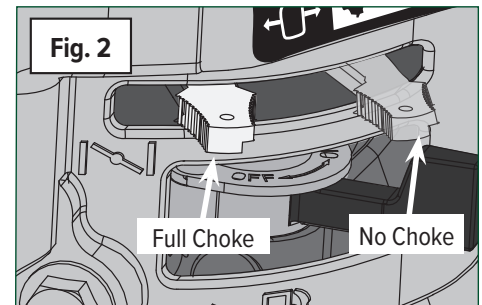
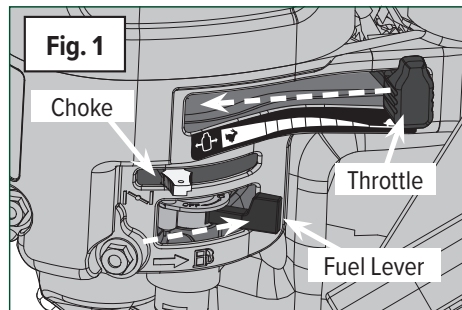

NOTE: When restarting a warm engine, use of the choke may not be necessary.

STOPPING THE XR950-PRO ENGINE

1. **(Fig. 3)** First, **move the throttle lever right to the slow position (turtle)** for 15-30 seconds to idle down the engine. Then continue to **move the throttle lever all the way to the right ("Stop" position)**. After the engine stops, **move the fuel lever left to the closed position.**

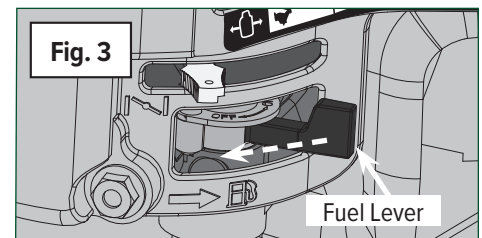

CHAPTER 4

WARRANTY & MAINTENANCE

PROTECT YOUR INVESTMENT— PLEASE READ CAREFULLY

Your Cyclone Rake® SPS-10 is fully warrantied against defects in materials and workmanship for a period of two years from date of delivery for home use and 6 months for commercial use. It's very similar to a new car warranty. If we did anything wrong in building your Cyclone Rake SPS-10, we will fix it. The owner is responsible for routine maintenance including oil changes, air filters and spark plugs.

NOTE: *Our Engine Maintenance Kit includes everything you need: air filter, oil, spark plug, spark plug wrench, fuel stabilizer, funnel, and shop towel. Order on-line or by phone.*

WHAT'S NOT COVERED

Just like your new car warranty, you are **not covered for collision damage, accidents, abuse, improper storage or failure to perform basic maintenance**, like changing the engine oil, spark plug and air filter. Good news: There should be no need for out-of-warranty service if you follow these simple guidelines.

ENGINE MAINTENANCE

Your engine is the most costly component of your Cyclone Rake. To maintain your warranty and to ensure long life, you must do five things:

- *Change the engine oil after the first 5 hours of operation.*
- *Change the engine oil every 20 operating hours.*
- *Always add fuel stabilizer per Briggs & Stratton's instructions.*
- *Change or clean the air filter at least annually, and never run the engine without the air filter.*
- *Change the spark plug annually.*



CHANGING THE ENGINE OIL:

1. **(Fig. 1A)** There are two **YELLOW** plastic "butterfly" at the base of the engine. Remove either one.
2. **(Fig. 1B)** Place a shallow pan under the engine and remove the metal drain. Drain until oil flow stops.
3. Replace drain plug and **tighten firmly**.
4. Place a rag under the butterfly cap opening.
5. **(Fig. 2)** Using a small funnel, slowly pour oil into the opening **until the oil reaches the bottom edge of the butterfly hole**.
6. Replace the butterfly plug and **tighten firmly by hand**. Wipe up any spilled oil.
7. Oil capacity is approximately **18-20 ounces for the XR950-PRO**.

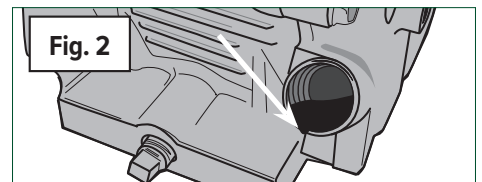
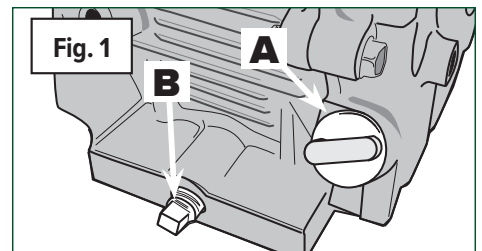

RECOMMENDED OIL CHART

The oil should be marked A.P.I. service "SF," "SG," "SH," "SJ" or higher.

| Air Temperature | Type of Oil |
|-----------------------|-------------------------|
| Above 32° F | SAE 30 or SAE 10W30 oil |
| Below 32° F | SAE 5W30 oil |

*If synthetic oil is preferred 5W-30 is good in all temps.
SAE 10W40 is specifically not recommended.*



CHANGING THE AIR FILTER

Like oil changes, we recommend an air filter inspection every 20 hours of operation. Regular inspection and replacement will ensure full engine power and prolong engine life.

NOTE: NEVER run your engine without an air filter. This will void your warranty!

1. **(Fig. 1)** Unscrew the knob at the top of the air filter housing.
2. **(Fig. 2)** Lift the housing to expose the air filter.
3. **(Fig. 2)** Remove the wing nut that secures the filter to the housing.
4. **(Fig. 3)** Remove the foam pre-filter.
5. **(Fig. 4)** Remove the filter. Loosen the debris by gently tapping the filter on a hard surface. If the filter is excessively dirty, replace with a new filter.
6. Wash the pre-filter in liquid detergent and water. Squeeze dry in a clean cloth. Allow it to air dry thoroughly.
Do not oil the pre-filter.
7. Place the dry pre-filter over the air filter, place them onto the threaded rod and secure with the wing nut.
8. Replace the filter housing and secure with the plastic knob.

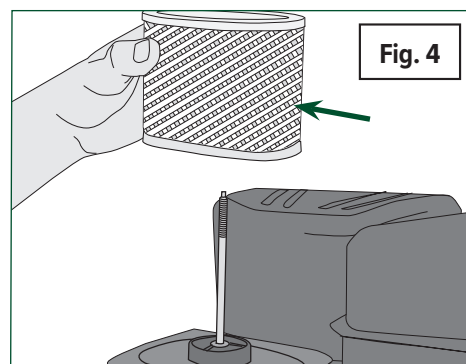
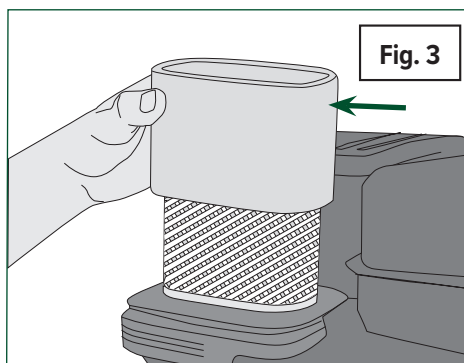
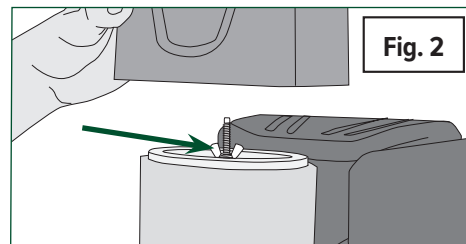
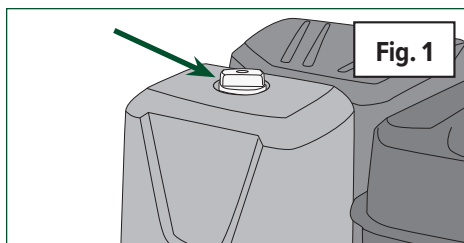

REPLACING THE SPARK PLUG

We recommend replacement once a year. Replace with **Bosch FR8DCX** spark plug or equivalent. The spark plug gap should be 0.030.

GENERAL MAINTENANCE

CHECK BOLTS & FITTINGS

The Cyclone Rake SPS-10 is subject to strong vibrations during operation. Take a few seconds each time you set up to check that all bolts and fittings are tight. If anything has loosened, tighten it. If you sense unusual vibration when operating, immediately stop the engine and check things out. This is particularly important the first few times you use your Cyclone Rake SPS-10.

MAINTAINING THE LATCHES

We recommend lubricating all your Cyclone Rake latches with WD-40 every six months.

NOTE: *One quick spray is sufficient. Do not over lubricate.*

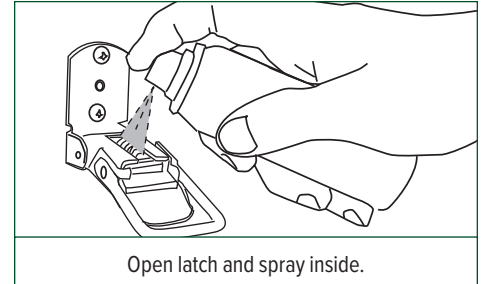

STORING YOUR SPS-10®

NOTE: *We recommend adding fuel stabilizer, per Briggs & Stratton's instructions, to your gasoline storage container each time you refill at the gas station.*

SHORT TERM STORAGE

Do not store the Cyclone Rake SPS-10 outdoors for extended periods. House it, like any good equipment, in a dry sheltered place.

If possible, find a heated, indoor spot. Make sure to thoroughly clean out the Fabric Collector Bag and Collector Cap and all the hoses of debris buildup.

LONG TERM STORAGE

Fuel can become stale when stored over 30 days. Stale fuel causes acid and gum deposits in the fuel system or essential carburetor parts.

To keep fuel fresh, **always add fuel stabilizer per Briggs & Stratton's instructions. This is available at any hardware store or in our Engine Maintenance Kit.** There is no need to drain gasoline from the engine if a fuel stabilizer is added. Run the engine for two minutes to circulate the stabilizer throughout the fuel system before storage. If gasoline in the engine has not been treated with stabilizer, it must be drained into an approved container. Run the engine until it stops from lack of fuel. **See your Briggs & Stratton® Operating and Maintenance Manual for further details.**

CHAPTER 5

OPERATING TIPS & TROUBLESHOOTING GUIDE**OPERATING THE CYCLONE RAKE SPS-10****EYE PROTECTION**

Always wear eye protection, as with any power tool. That's why we've included safety goggles.

OPERATING NOISE

With an engine running, there's no way to avoid noise. Whenever you operate loud machinery, you should always wear hearing protection. That's why we've included a pair of disposable ear plugs. You can get replacements inexpensively at most hardware stores. Or use power equipment "ear muffs" found at any good hardware store or home center.

BLOWER MODE TIPS

- Make consecutive passes across property to collect leaves into one or more piles.
- When you've finished blowing your debris into piles, position your SPS-10 near (within 15 ft) a pile before changing to Collector mode.

COLLECTION MODE TIPS

The Power Vacuum Pickup(PVP) is a great tool and will lift just about anything it touches. **DO NOT use it on dangerous materials like rocks, glass, trash, metal scraps, etc.** Watch out for hidden rocks, glass, metal, etc. **Remove them before you vacuum.** Never vacuum up anything except organic lawn debris.

- Use PVP to vacuum one pile at a time, keeping the wand slightly above the leaves and using a (slow) back and forth motion to prevent vacuuming too much at once.
- The municipal bag and fabric bag will take approximately 2 minutes to fill to capacity (time will vary based on debris type and weight).
- Keep an eye on the SPS-10 Hose, when you start to see debris swirling in place, it is most likely full. After a few fill-ups you should develop a sense of the time it takes to fill a Collector bag.
- If the leaves and debris have become heavy, wet and matted (for example, uncleared debris from a previous season) then do the job in two steps. Go over the top layer. Then give the remaining leaves a day or two to dry out. A second pass should get them all.

PROTECTING HOSES

Don't drag your Power Vacuum Pickup™ hose over curbs, stone walls or piles of cut branches. They're tough, but they do puncture on sharp objects. And please store your hoses out of direct sunlight as this will cause your hose (or any plastic) to degrade over time.

TROUBLESHOOTING GUIDE

| PROBLEM | POSSIBLE CAUSE | CORRECTION |
|--|--|--|
| Leaves are escaping the paper bag during collecting. | <ol style="list-style-type: none"> 1. Corrugated Collector Insert is more than ½” above the platform. 2. Collected material is too small or has been previously mulched. 3. The municipal bag may have tears. 4. The Corrugated Collector Insert may be damaged. | <p>During normal operation, the bag should self-seal within 20-30 seconds. If it takes longer, confirm that:</p> <ol style="list-style-type: none"> 1. Corrugated Collector Insert is no more than ½” above the platform. If not, adjust platform straps. 2. Avoid vacuuming mulched debris. 3. Inspect municipal bag for tears. 4. Inspect Corrugated Insert for damage. |
| Debris is escaping between metal Collector Frame and Collector Cap. | <ol style="list-style-type: none"> 1. The rubber seals are not attached to the metal Collector Frame. 2. The Collector Frame is not all the way into the slots underneath the Collector Cap. | <ol style="list-style-type: none"> 1. Check to make sure rubber seals are attached to the Frame. If the seals are not attached, the adhesive may be worn out. <ul style="list-style-type: none"> • Order new seals if they look damaged. 2. Make sure the Collector Frame is all the way into the slots underneath the Collector Cap. |
| The Collector is tilting during operation. | <ol style="list-style-type: none"> 1. The Clamp Brackets and Knobs are missing. 2. The Bag Platform is more than half an inch below the Corrugated Collector Insert. | <ol style="list-style-type: none"> 1. Ensure the Clamp Brackets and Knobs are present and tightened to restrict movement. 2. Make sure the Bag Platform is no more than half an inch below the bottom of the Corrugated Collector Insert. If not, adjust Platform Straps. |
| The Collector Frame will not come out of the Collector Cap. | <ol style="list-style-type: none"> 1. The SPS-10 may be overfilled. | <ol style="list-style-type: none"> 1. Push the Collector Frame all the way in, remove blower nozzle from the Collector Cap and push debris in the collector down. |
| How do I know if the paper bag is filled? | | The debris will begin swirling in the clear SPS-10 Hose after approximately 2 minutes after starting a new municipal bag. |
| There is a lack of suction. | <ol style="list-style-type: none"> 1. Clog in the Power Vacuum Pickup hose. 2. The hose is twisted upon its self. 3. The engine may not be at full-throttle. | <ol style="list-style-type: none"> 1. Gently shake the hose to dislodge clog. 2. Keep PVP hose straight if possible to reduce chances for clogs. 3. Check the engine and make sure it's at full throttle. |
| The Blower is not strong enough. | <ol style="list-style-type: none"> 1. The Inlet Cover is not attached to the blower opening. 2. The Safety Cover has flipped closed on the blower opening. 3. Blower housing is clogged with debris. | <ol style="list-style-type: none"> 1. Attach the Inlet Cover. 2. Attach the Inlet Cover. 3. Make sure the engine has had time to cool. Remove the spark plug wire. Disconnect any hoses attached to the housing, and check for any debris inside the blower housing. Remove any debris, re-attach items then re-start the engine. |
| The Collector Frame does not fit into Collector Cap. | <ol style="list-style-type: none"> 1. Debris may be stuck in the tracks. 2. Rubber seals may have come detached. | <ol style="list-style-type: none"> 1. Check/ remove debris stuck in the track at the bottom of the Collector Cap. <ul style="list-style-type: none"> • It may help to remove debris from Collector Cap with a few gentle taps after each load. • If the tray does not slide in and out easily, spray some dry lube inside the track at the bottom of the Collector Cap. 2. Ensure rubber seals are properly attached at all points. |
| There is excessive or violent vibration. | <ol style="list-style-type: none"> 1. The bolt may have come out of the impeller. 2. The Impeller might have broken, or fan might have separated from the hub. | <ol style="list-style-type: none"> 1. Check the impeller, if loose, replace the impeller. <ul style="list-style-type: none"> • <i>Always check your Impeller and Impeller bolt before each use.</i> |

TROUBLESHOOTING GUIDE

| PROBLEM | POSSIBLE CAUSE | CORRECTION |
|---|---|--|
| The handlebar height adjustment knobs are vibrating loose. | 1. The rubber washers are missing. | 1. Check to make sure the rubber washers are being used and the knobs are tightened well. • <i>Always check your knobs before each use.</i> |
| The Nozzle Dock will not stay in place. | 1. The spring of the Nozzel Dock is missing or maybe damaged. 2. The Blower Nozzel is not inserted properly. | 1. Verify that the Nozzle Dock spring is present and attached at both ends. • Order new Spring if damaged or missing. 2. Verify Blower Nozzle Bracket is being inserted behind the pin of Nozzle Dock. |
| The wheels shake. | 1. The washers and U-bolts may be loose. | 1. Verify that the wheel's washers and U-bolts are tightened. |
| Engine will not start (pull- start). | 1. Fuel tank empty, or stale fuel. 2. Spark plug wire is disconnected. 3. Faulty spark plug. 4. Fuel shut-off lever not in the correct position. 5. Throttle control lever not in the correct position. | 1. Gas should be fresh, clean gas. If the gas is old change it. If you keep gas longer than 30 days, always add an ethanol specific fuel stabilizer per Briggs & Stratton's instructions. 2. Connect the wire to the spark plug. 3. Clean, adjust gap or replace the spark plug. 4. Place the fuel shut-off lever to the "ON" position. 5. Slide the throttle control all the way to the right (rabbit). |
| The engine is smoking. | 1. Oil level incorrect. 2. Incorrect type of oil. 3. Air filter is dirty. 4. Operating on a steep incline. | 1. Check the oil level and adjust accordingly. (See Briggs & Stratton owner's manual). 2. Check that you are using the proper oil. 3. Clean or replace the air filter. 4. Travel up and down slopes, avoid going across slopes. Avoid blowing on slopes more than 15 degrees. |
| The recoil will not pull or is difficult to pull. | 1. Blower housing is clogged with debris. 2. Oil level is low. 3. The recoil is tangled up on itself. 4. There is debris in the recoil. | 1. Make sure the engine has had time to cool. Remove the spark plug wire. Disconnect any hoses attached to the housing, and check for any debris inside the blower housing. Remove any debris, re-attach items and try re-starting the engine. 2. Check the engine oil level, the engine may be seized. Fill oil if necessary. (See Briggs & Stratton owner's manual.) 3. Disconnect the spark plug wire, reach into the blower housing. Slowly turn the impeller by hand counter-clockwise, at the same time pull the starter cord. The rope should pull out. Reconnect the spark plug and try re-starting the engine. 4. Locate and remove the 4 bolts that secure the recoil housing to the engine. Remove housing, check for debris and clean if necessary. Re-install the housing and try re-starting the engine. |
| The Engine is not running smoothly. | 1. Choke is in the incorrect position. 2. Air filter is dirty. 3. Spark plug is faulty. 4. Gas is old. 5. Oil is not at the proper level or is dirty. | 1. Once the engine has started the gray choke lever should be all the way to the left or full choke position. 2. Clean or replace the air filter. 3. Clean, adjust gap or replace the spark plug. 4. Gas should be fresh, clean gas. If the gas is old change it. If you keep gas longer than 30 days, always add an ethanol specific fuel stabilizer per Briggs & Stratton's instructions. 5. Check the oil level and adjust accordingly. (See Briggs & Stratton owner's manual.) If dirty, change the oil per the instructions in the owner's manual. |

CHAPTER 6

SERVICE PARTS

CHASSIS

| Ref. # | Part Name | Part # |
|--------|---|-----------|
| 221 | Tire & Wheel Assembly | 01-01-826 |
| 816 | Chassis Complete with wheels-SPS | 12-04-003 |
| 817 | Chassis Frame | 12-02-003 |
| 817a | Chassis Frame with axles | 12-03-003 |
| 818 | Nozzle Dock Assembly | 12-02-010 |
| 819 | Extension Spring | 12-01-013 |
| 820 | 5/16-18 x 5.25 x 0.875 Hex bolt | 12-01-014 |
| 821 | Axle Brace | 12-01-005 |
| 822 | Wheel Axle | 12-01-006 |
| 823 | 1/4"-20 Black Oxide nylon lock nut | 12-01-094 |
| 824 | 1/4-20 x 3/4 x1-1/4 U bolt | 12-01-007 |
| 825 | Cotter Pin 1/8 dia 2-5/8 long | 12-01-008 |
| 826 | 5/16-18 x 0.625 Hex flange bolt | 12-01-009 |
| 827 | Wheel Hardware Kit: (4) axle cotter pins, (12) axle washers | |

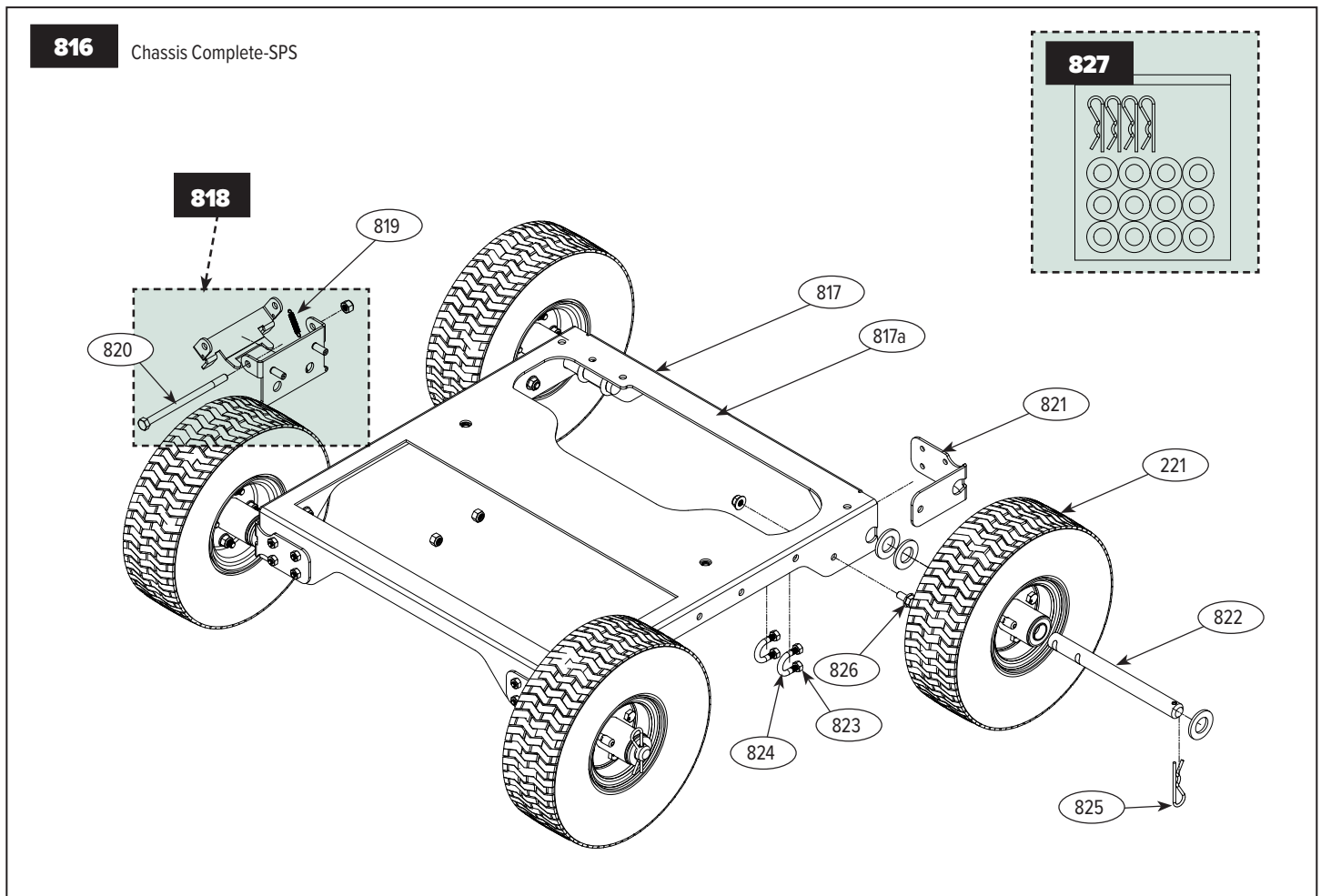

HANDLEBARS

| Ref. # | Part Name | Part # |
|--------|---|------------|
| 055 | Rubber washer | 01-01-1990 |
| 828 | Strap for Platform | 12-01-070 |
| 829 | Lower Handlebar | 12-02-015 |
| 830 | Platform Locking Bracket | 12-02-062 |
| 831 | Cotter Pin for 1/4"-3/8" Pin | 12-01-066 |
| 832 | Bag Caddie | 12-01-067 |
| 833 | Upper Handlebar | 12-02-017 |
| 834 | Collector Cap Pin | 12-01-018 |
| 835 | 5/16-18 x 1.5 Round head square neck bolt | 12-01-020 |
| 836 | Handlebar Knob | 12-01-021 |
| 837 | Bag Platform w/straps | 12-02-022 |
| 838 | Bag Platform | 12-01-022 |
| 839 | Clevis and Cotter Pin | 12-01-023 |
| 840 | Handlebar to Chassis Hardware Kit: (4) 5/16-18 x 1.5 Hex bolts | 12-01-088 |
| 841 | Handlebar Hardware Kit: (4) Knobs, (4) Carriage bolts, (4) Rubber washers | 12-01-087 |
| 842 | Handlebar Lock Bracket Hardware Kit: (2) 5/16-18 x 1.5 Hex bolts, (2) 5/16-18 x 1.75 Hex bolts, (4) 5/16-18 nylon lock nuts | 12-01-091 |
| 843 | Platform Hardware Kit: (2) Clevis & Cotter pins | 12-01-092 |
| 844 | Collector Cap Pins, set of 2 | 12-01-093 |
| 845 | Strap for Platform, set of 2 | 12-02-070 |
| 846 | Handlebar Knobs, set of 2 | 12-02-021 |

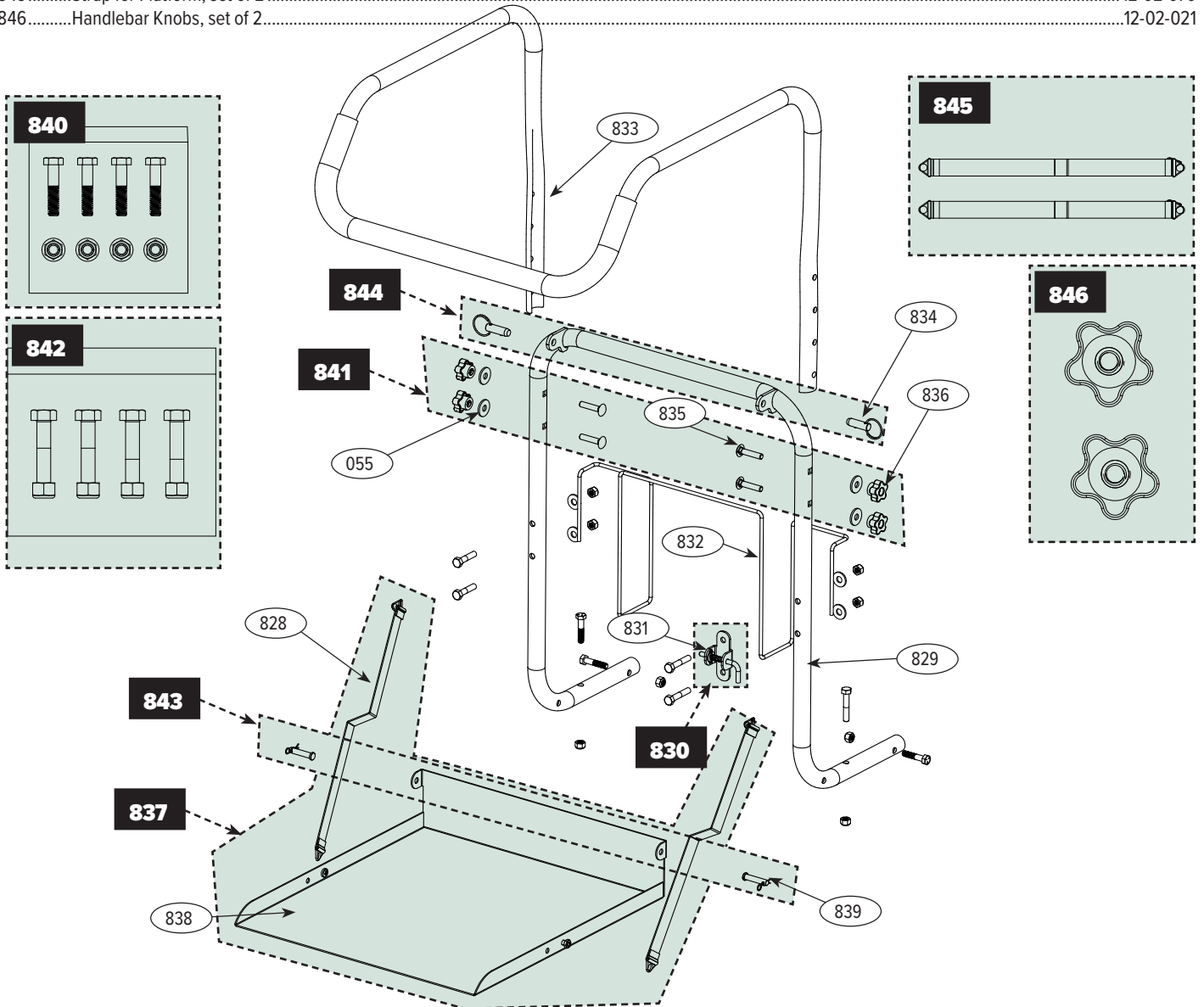

COLLECTOR

| Ref. # | Part Name | Part # |
|--------|---|------------|
| 055 | Rubber washer | 01-01-1990 |
| 554 | Clamp Bracket and Knob (rubber washer is not included) | 01-02-121 |
| 847 | Collector Cap Complete - SPS | 12-03-026 |
| 848 | Top Screen - SPS | 12-02-029 |
| 849 | Collector Cap Top | 12-02-048 |
| 850 | 1/4-20 x 0.5 Black oxide steel pan head Phillips screw | 12-01-041 |
| 851 | 8" X 3/64 Wire lanyard | 12-01-068 |
| 852 | Corrugated Collector Insert Complete w/Frame | 12-02-037 |
| 853 | Corrugated Collector Insert | 12-01-037 |
| 854 | Metal Collector Frame with Seals | 12-02-038 |
| 855 | Metal Collector Frame | 12-01-038 |
| 856 | Right Collector Hinge | 12-02-036 |
| 857 | Left Collector Hinge | 12-02-035 |
| 858 | Top Docking Bracket Assembly | 12-03-034 |
| 859 | Collector Frame Hardware kit: (14) 10-24 x 0.25 screws, (14) T-nuts | 12-01-090 |
| 860 | Seals for Metal Frame | 12-02-040 |
| 861 | Fabric Collector Bag Complete w/Frame | 12-03-049 |
| 862 | Fabric Collector Bag | 12-02-049 |

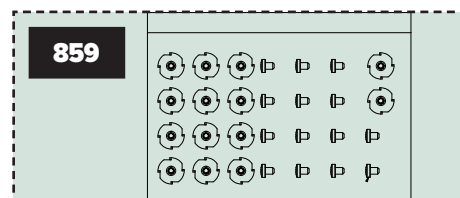
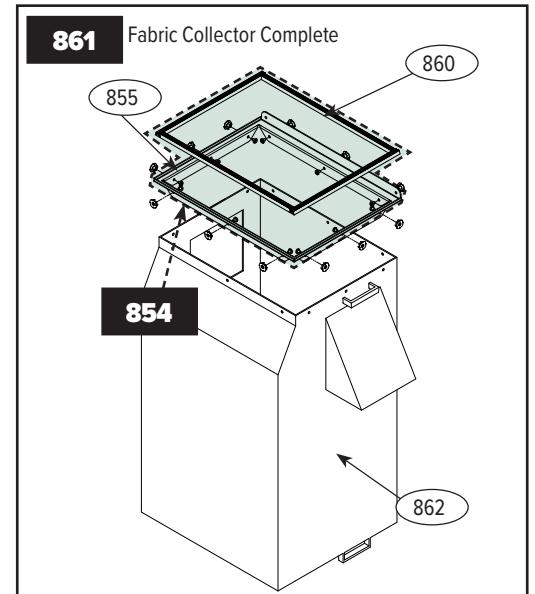
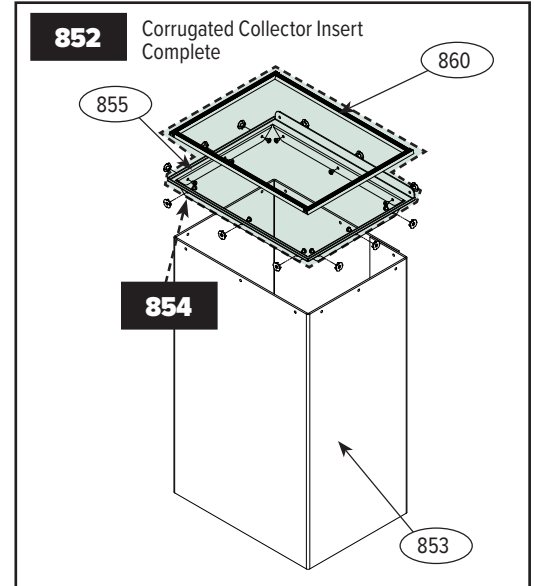
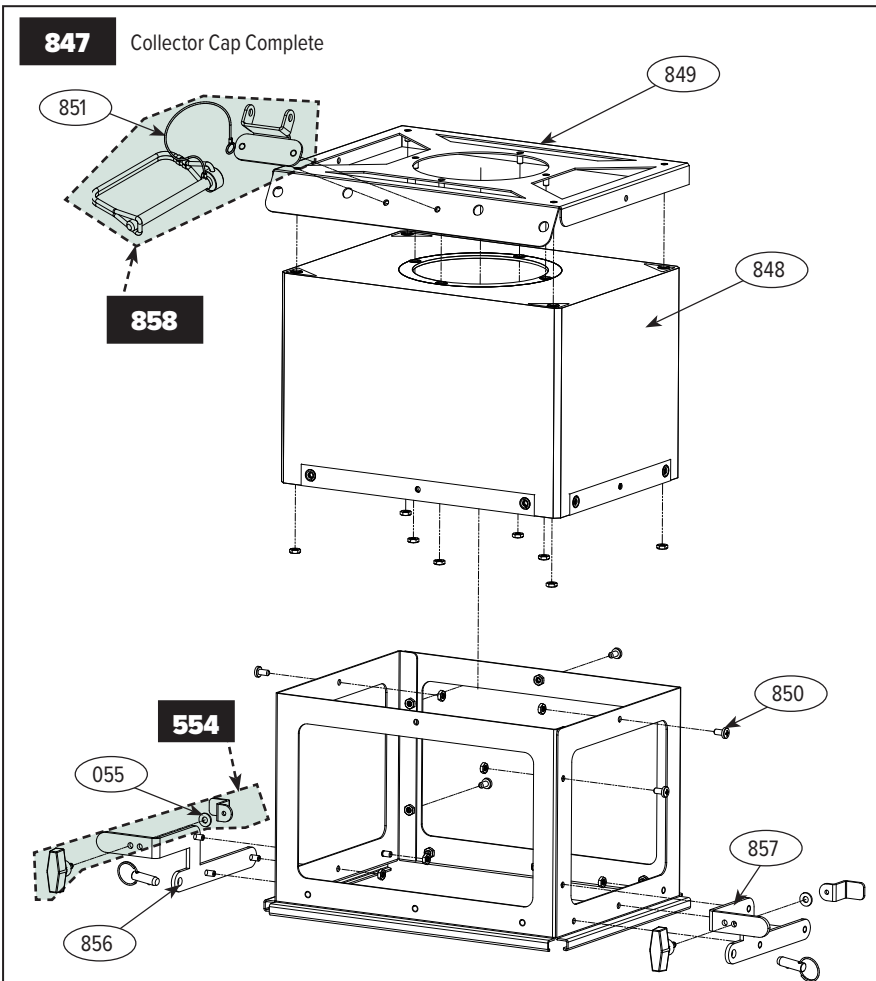

HOSE ASSEMBLY

| Ref. # | Part Name | Part # |
|--------|---|-------------|
| 489 | Latch w/hardware - set of 2 | 01-03-045 |
| 863 | Hose Assembly Complete - SPS | 12-03-001 |
| 864 | Exit Chute Complete - SPS | 12-02-002 |
| 865 | Blower Nozzle Complete | 12-02-001 |
| 866 | 1/4-20 x 0.875 Pan head machine screw | 12-01-052 |
| 867 | Blower Inlet cover | 12-02-057 |
| 868 | 1/2 x 1 Male-Female threaded hex standoff | 12-01-061 |
| 869 | 7x6 SPS Hose | 12-01-047 |
| 870 | 7 in Right Handed Bridge Type Band Clamp | WHBCBT-07-R |

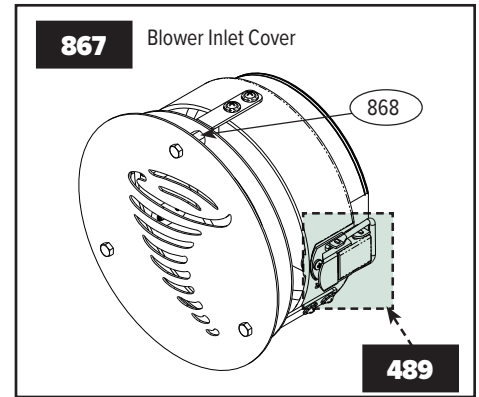
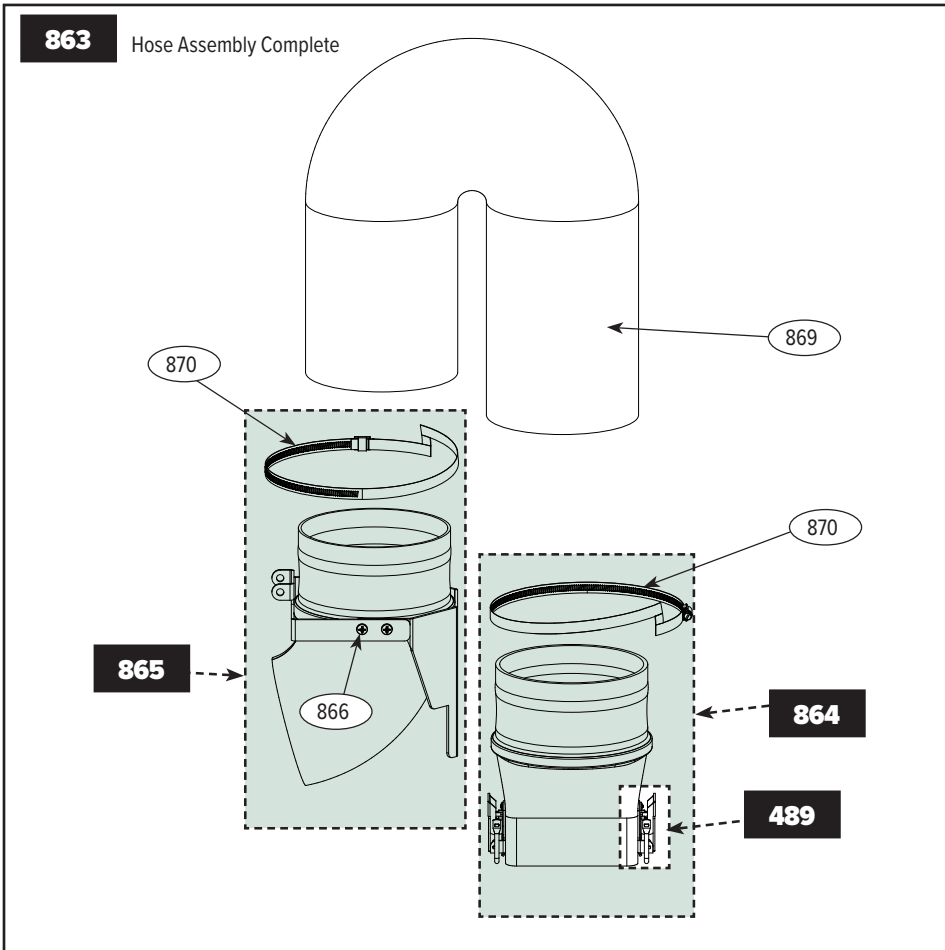

ENGINE - B&S XR950-PRO ENGINE

| Ref. # | Part Name | Part # | Ref. # | Part Name | Part # |
|--------|--|------------|--------|---|------------|
| 162 |1" Cap plug - black (set of 4) | 09-02-055 | 525 |Air filter cover knob - plastic..... | 01-01-1744 |
| 164 |Engine frame w/cap plugs | 05-02-003 | 526 |Wing nut - air filter..... | 01-01-1745 |
| 172a |Engine clamp handle w/rubber washers (set of 2) | 01-02-681 | 560 |Carbon canister gas cap..... | 01-01-782 |
| 302t |Engine - B&S - XR950-PRO | 04-02-302 | 568 |Caster wheel w/nut & washer for engine frame (set of 4) | 01-02-126 |
| 303c |Butterfly dipstick - XR950-PRO & Cyclonic engine..... | 01-01-2151 | 570 |Engine handle w/hardware, B&S XR950-PRO | 01-03-2109 |
| 304 |Spark plug, Bosch FR8DCX or equiv..... | 01-01-758 | 584 |Air & foam filters, B&S XR950-PRO..... | 01-01-2116 |
| 310c |Recoil starter, B&S XR950-PRO | 01-01-2113 | | | |
| 501a |Exhaust deflector w/hardware..... | 01-01-1331 | | | |

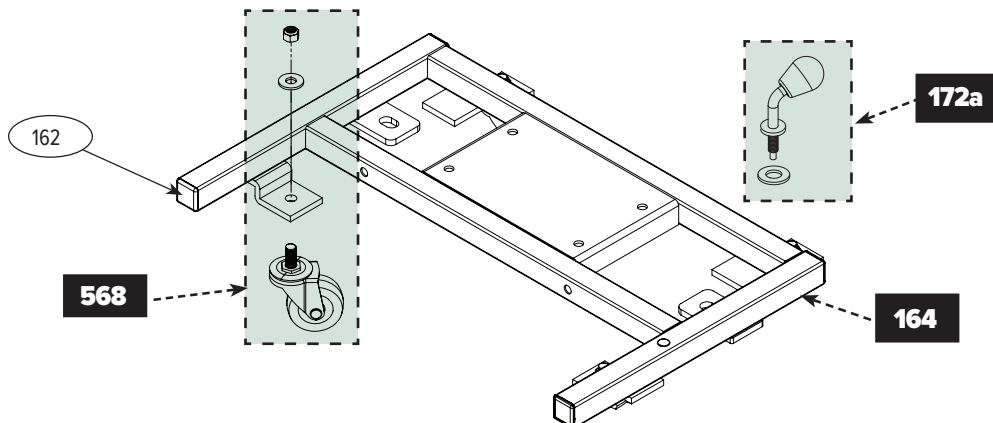
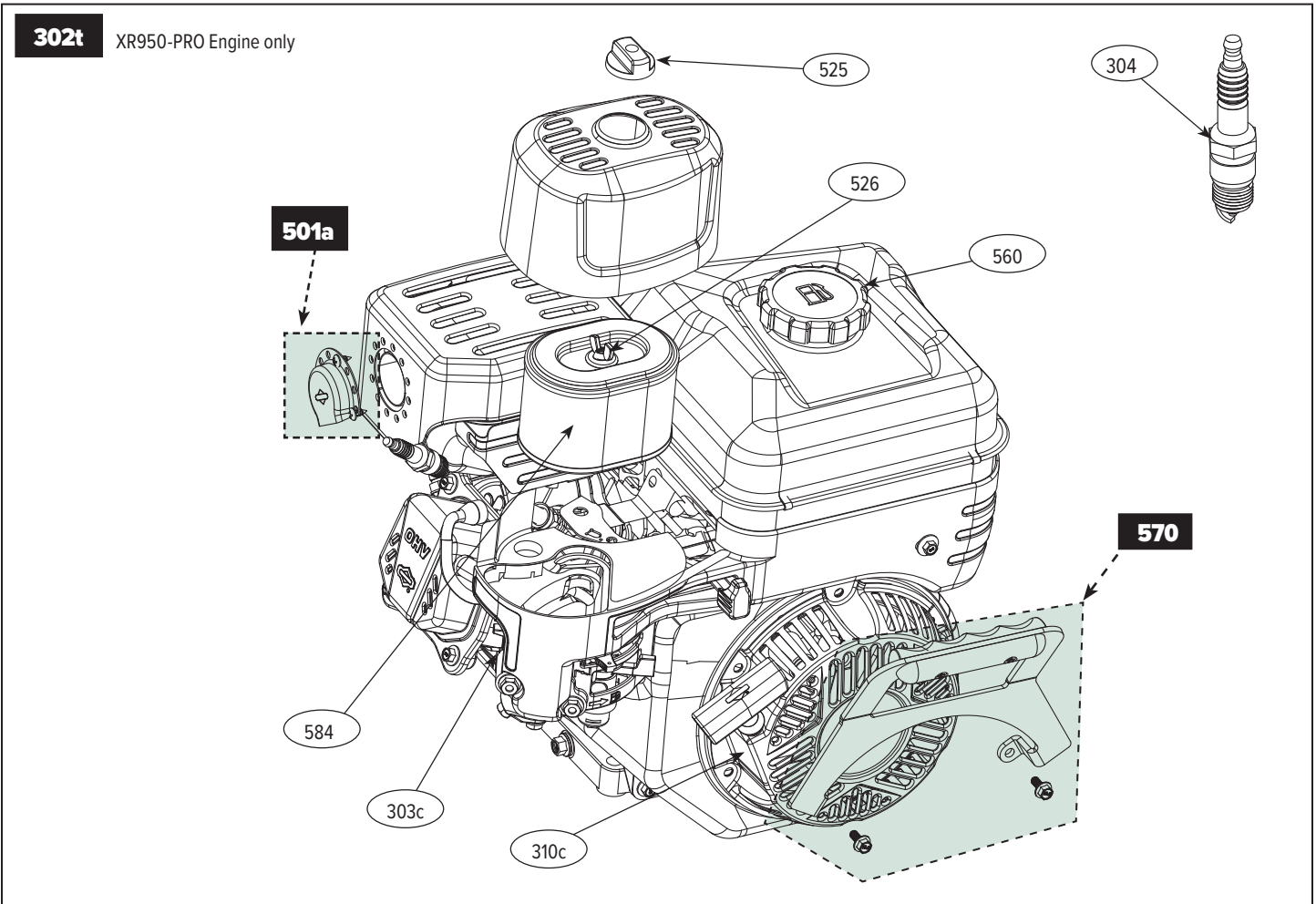

BLOWER UNIT - B&S XR950-PRO

| Ref. # | Part Name | Part # |
|--------|---|------------|
| 269 | 10-24 x 1/2" Truss head screw | 01-01-563 |
| 276 | Safety cover hinge bracket w/t-nut & screw | 01-02-261 |
| 278b | 8" Safety cover w/bolt & nut | 01-02-1160 |
| 289 | Blower liner nut (special part - 8 req'd) | 01-01-145 |
| 298 | Blower front handle w/hardware | 01-03-1866 |
| 445 | 8" Blower housing replacement kit - std liner (no impeller) | 01-03-1039 |
| 449 | 8" Blower Unit replacement kit, - std liner & 4-blade impeller - SPS-10 | 01-04-1039 |
| 454 | Yellow 4-blade impeller replacement kit for XR950-PRO engine | 02-03-017 |
| 489 | Latch w/hardware (set of 2) | 01-03-045 |
| 523 | Standard strike, w/hardware (set of 4) | 01-02-564 |
| 571 | Exit plate w/studs, wide strike & nuts | 01-02-128 |
| 815 | Blower Unit Complete- XR950-PRO engine, 4-blade impeller & std liner - SPS-10 | 12-04-510 |

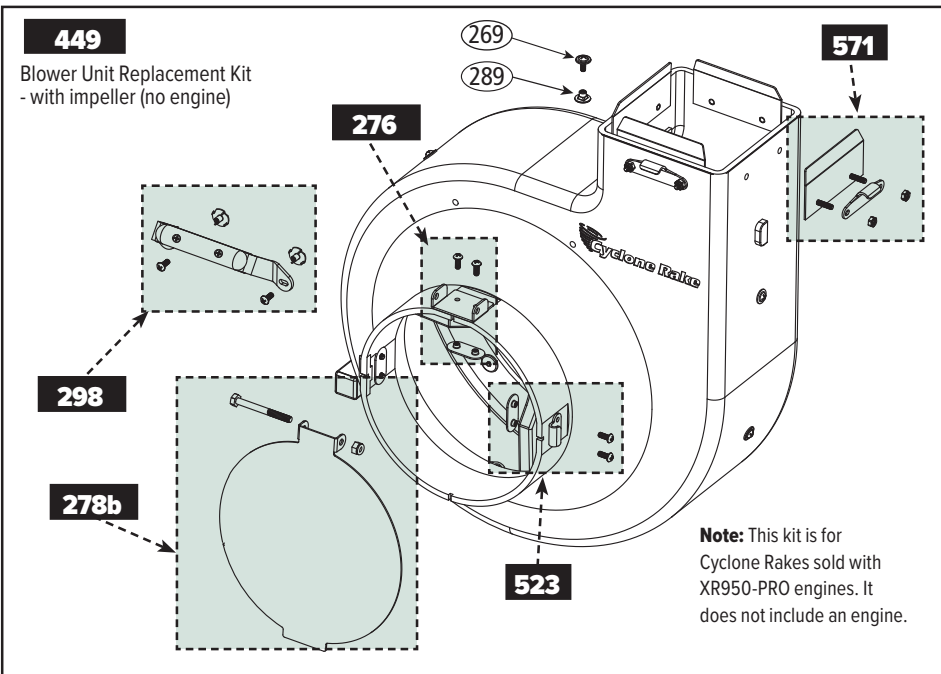
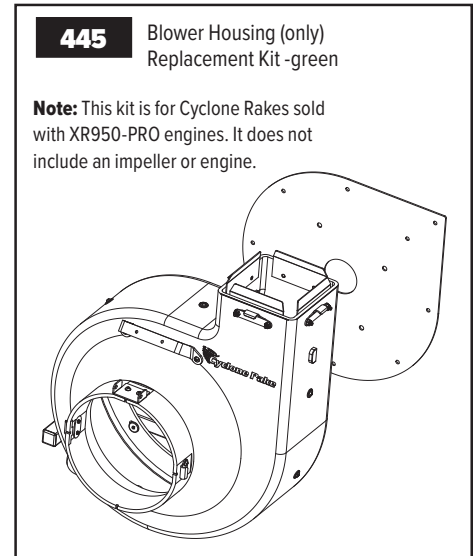
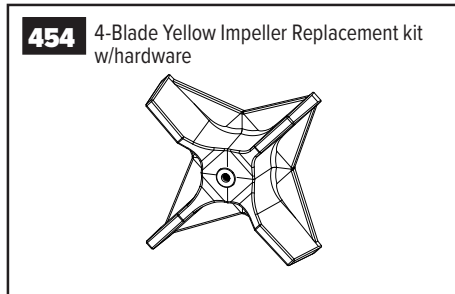
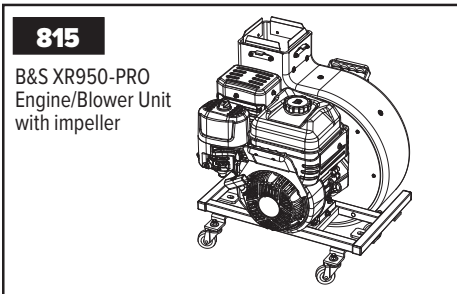

POWER VACUUM PICKUP

| Ref. # | Part Name | Part # |
|--------|--|------------|
| 27 | 6" Band clamp, bridge type | 01-02-024 |
| 28a | 15 ft.- PVC (green), 6" dia. | RPVC-06-15 |
| 37 | 10-24 x 1/2" Round head screw | 01-01-173 |
| 54 | 7" Band clamp, bridge type | 01-02-023 |
| 109 | 5/16-18 x 1.75" Carriage bolt | 01-01-1034 |
| 112 | Spring clip | 01-01-1109 |
| 114 | Strap w/ spring clip | 01-04-055 |
| 473a | Power Vacuum Pickup, complete as boxed - PVC (green) | 225 |
| 474b | Wand, complete w/handles & shoulder strap | 01-04-2120 |
| 475a | 6" x 8" Power Vacuum collar, complete w/latches | 01-02-137 |
| 489 | Latch w/hardware (set of 2) | 01-03-045 |
| 523 | Standard strike w/hardware (set of 4) | 01-02-564 |
| 555 | Inner & outer hose clamp w/screw | 01-02-122 |
| 650 | 1/4"-20 Eye bolt | 01-01-2129 |
| 651 | 1/4"-20 Acorn nut | 01-01-2130 |
| 652 | 5/15"-18 Nylon flange nut | 07-01-151 |
| 653 | Side handle tube w/grip | 01-02-2124 |
| 654 | Handle tube w/grip | 01-02-2122 |
| 655 | Molded wand inlet w/bracket | 01-02-2120 |

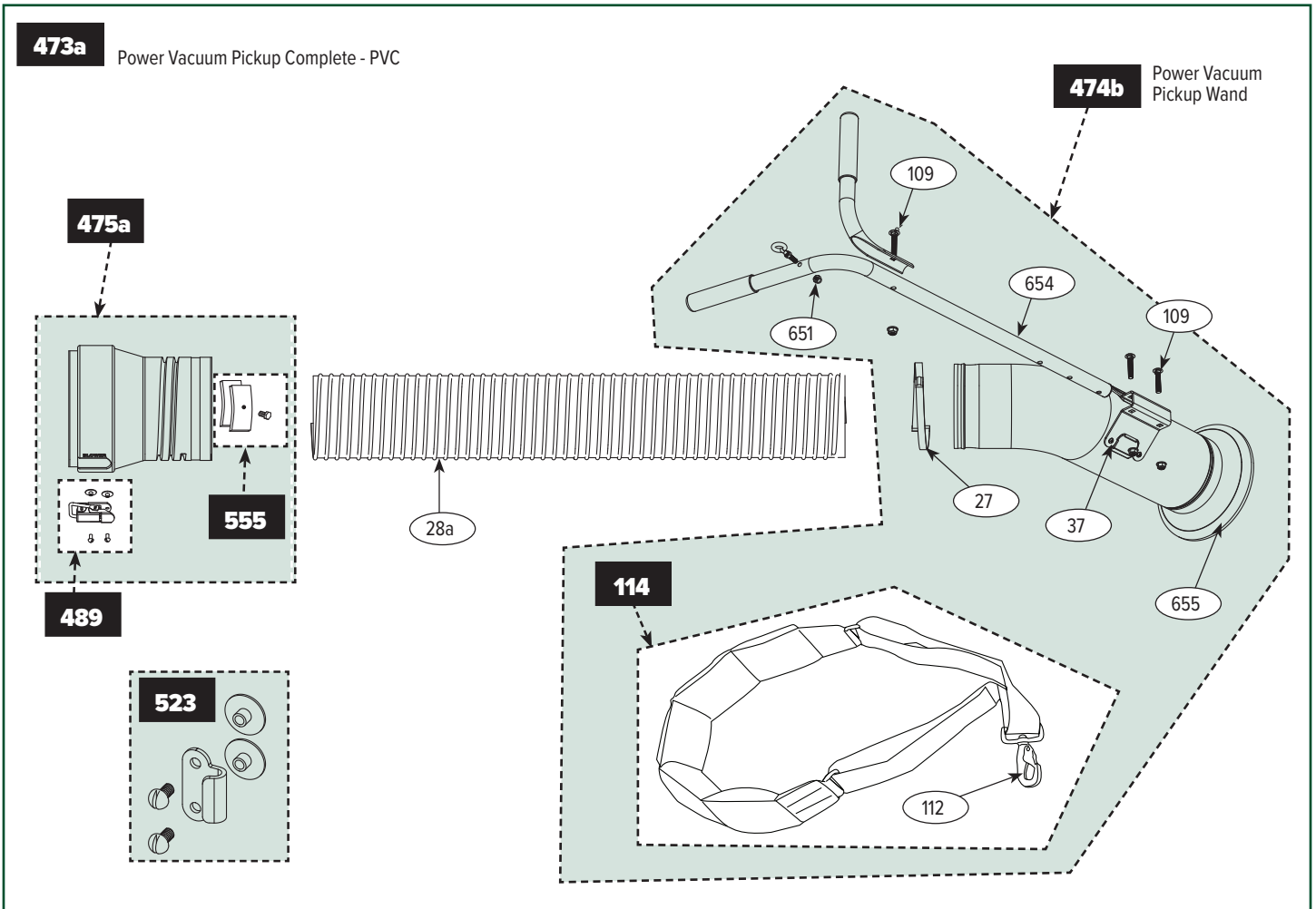



MANUFACTURER'S WARRANTY

CYCLONE RAKE SPS-10 - RESIDENTIAL USE

Your new Cyclone Rake SPS-10 with the Briggs & Stratton® XR950-PRO engine is covered under a bumper-to-bumper warranty for two year from the date of delivery for residential use. This covers you against any defects in materials and workmanship. This two year engine warranties is covered by Briggs & Stratton® directly. You are responsible for routine maintenance including (but not limited to) oil changes, air filters, and spark plugs. ***Collision damage and normal wear/age damage are not covered under the warranty.***

CYCLONE RAKE SPS-10 - COMMERCIAL USE

Your new Commercial use Cyclone Rake SPS-10 with the Briggs & Stratton® XR950-PRO engine is covered under a bumper-to-bumper warranty for six months from the date of delivery. This covers you against defects in materials and workmanship. This engine warranty is covered by Briggs & Stratton® directly. You are responsible for routine maintenance including oil changes, air filters, and spark plugs. ***Collision damage, and normal wear/age damage is not covered under the warranty.***

WOODLAND POWER PRODUCTS, INC.

KEEP THIS WARRANTY FOR YOUR RECORDS

REGARDING YOUR BRIGGS & STRATTON® ENGINE

Please refer to the separate Engine Operating & Maintenance Instructions included with your Cyclone Rake for detailed instructions on engine care and maintenance. Just like your new car, your engine warranty will be made void if you fail to maintain it. There are two things you must be sure to do: (1) Change the engine oil regularly. We recommend changing the oil after the first five hours of operation. Then, every 20 hours. (2) Never operate the engine without the air filter. Dust and grit can destroy it. Air filters should be changed at least once a year; more often if operating in very dusty environments or in commercial service. We also recommend **always adding fuel stabilizer to your gasoline** and replacing the spark plug once a year for peak engine performance. Be sure to use an exact replacement plug, as described in your Owner's Manual.

REPLACEMENT PARTS

We maintain a complete parts inventory and as well as manufacturer's approved engine maintenance kits available on-line at CycloneRake.com/store/owners-marketplace/parts/ or through our technical sales team.

If you have any questions regarding your Cyclone Rake, please contact us toll-free at 888-531-7253, or visit CycloneRake.com.

If you'd like to register your Cyclone Rake Warranty online please go to:

<https://www.cyclonerake.com/cr-warranty-registration/>

or just scan the QR code.



**We'd love to hear about your experience with
Woodland Power Products, Inc. please go online to:**

www.Trustpilot.com/review/cyclonerake.com

Your Cyclone Rake Model: _____

Date Delivered: _____

ASSEMBLING YOUR CYCLONE RAKE SPS-10 VIDEOS

We want to make assembling and using the Cyclone Rake SPS-10 as easy as possible. For that reason, you will find QR codes below and throughout your manual that you can access with your smart phone to watch videos that will help walk you through the assembly process.

Again, if you don't happen to have a smart phone, don't worry about it! All our assembly videos are also in one easy spot on our website. Simply type the link below into any web browser to watch all our assembly videos.

WWW.CYCLONERAKE.COM/SPS-10-ASSEMBLY-VIDEOS/



Attaching the Lower Handlebar



Attaching the Wheels



Attaching the Bag Platform



Attaching the Platform Lock and Bag Caddie



Attaching the Upper Handlebar



Installing the Engine/Blower Unit



Filling the XR950-PRO Engine with Oil



Assembling the Collector Cap



Attaching the Collector Cap to the Handlebars



Assembling the Collector Insert



Setting up for Blower Mode



Setting up for Collection Mode



Using Paper Collection Bags



Attaching the Power Vacuum Pickup



Removing the Collection Bags



Starting & Stopping the XR950-PRO Engine



Changing the Engine Oil on the XR950-PRO Engine



Changing the Air Filter on the XR950-PRO Engine



Replacing the Spark plug.



WOODLAND POWER PRODUCTS, INC.

72 Acton Street, West Haven, Connecticut 06516

TOLL-FREE 888-531-7253

www.CycloneRake.com