



Nozzle Docking Bracket Replacement Instructions

Follow the instructions below to replace the Nozzle Docking Bracket Assembly on your SPS-10.

TOOLS YOU'LL NEED: 1/2" wrench or socket

Remove old Nozzle Docking Bracket Assembly

1. Remove the Engine Unit from the Chassis and tip the Chassis on it's side. On the bottom of the chassis, locate and remove the two 5/16-18 nylon locknuts that are attached to the Docking Bracket using a 1/2" wrench or socket. Remove the old docking bracket.

Mount the new Nozzle Docking Bracket Assembly

2. Insert the PEM studs on the back of the new Blower Nozzle Docking Bracket into the two holes that the previous Bracket was removed from. Secure with the 2 nylon lock nuts.

That's it!

Your new Nozzle Docking Bracket is attached!

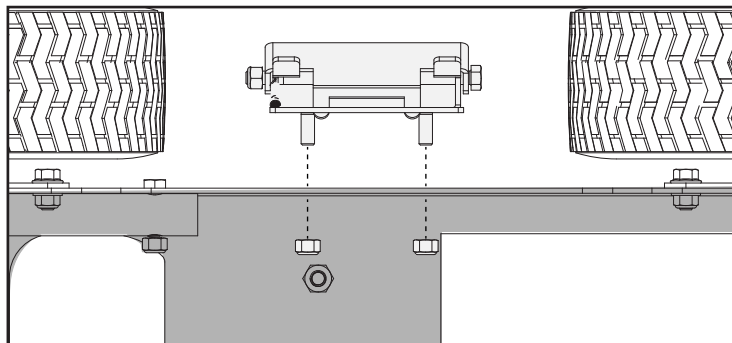
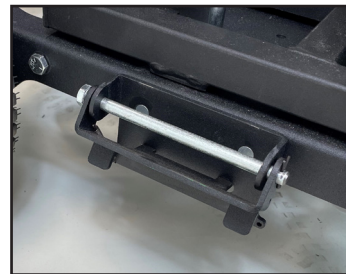

WOODLAND POWER PRODUCTS, INC.

72 Acton Street, West Haven, Connecticut 06516

www.CycloneRake.com

©2023, Woodland Power Products, Inc.

TOLL-FREE 1-(888)-531-RAKE

12-06-003 F23