

The extender brackets attach to the rear of your Cyclone Rake collector frame. They provide increased capacity for the collector bag, and also make dumping the contents far easier.

General Instructions

The extender brackets come as a right and left hand pair, just like shoes or gloves. You can attach either one first. Installation of the second bracket is identical. Also note that the black bolt and nut in the hinge brackets is just a shipping bolt. Discard it after removing it.

The J-hooks referred to in this instruction sheet are shipped attached to your Main Chassis. Look inside the tall thin chassis box. See Figure 1.

Assembly

1. Remove the small green shock cord from the aluminum tubes. Raise the tubes and lock them in place by moving the slider brackets down into the locked position (Figure 2). Do this on both sides of the collector bag.
2. At the rear of the collector bag, remove and discard the temporary shipping bolt and nut from the hinge bracket, as shown in Figure 3.
3. Place one extender bracket over the collector frame. Place the two carriage bolts through the bracket **with the round heads up**, as shown in Figure 4.
4. Place one of the J-hooks under the collector frame, as shown in Figure 5. **Be sure the hook faces in the direction shown.** Then fasten the carriage bolts with 2 nylon lock nuts. Tighten the nuts firmly. (Hint: place a finger on the round heads of the carriage bolts to prevent turning while you tighten the nuts).
5. Move the hinge bracket over the hole in the extender bracket. Bolt it in place using the 1 x 5/16 hex bolt, washer and nylon lock nut provided. See Figure 6.
6. Perform exactly the same steps on the opposite side of the collector frame to attach the second extender bracket.

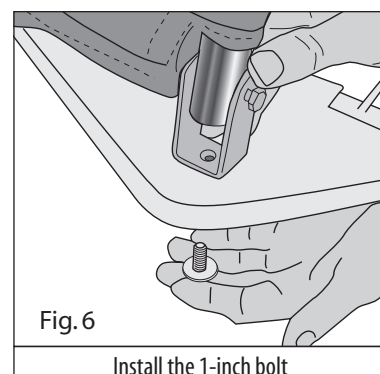
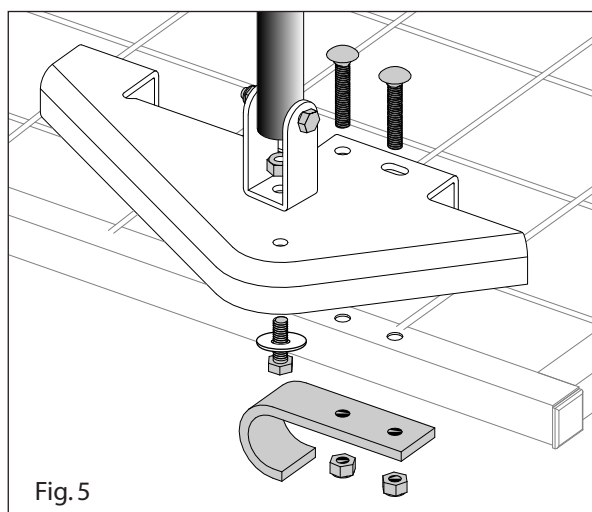
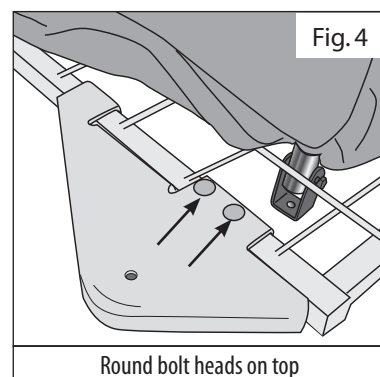
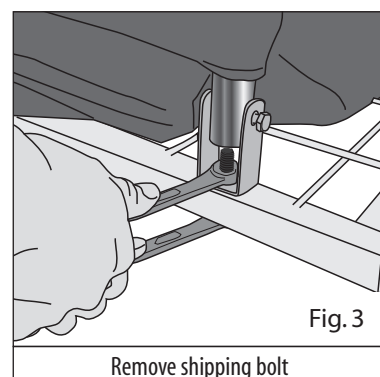
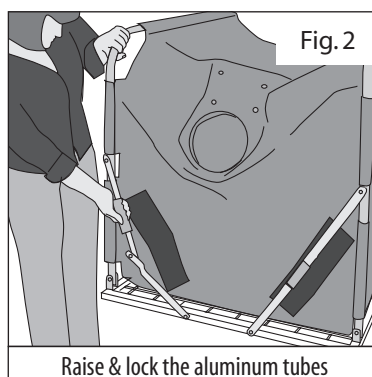
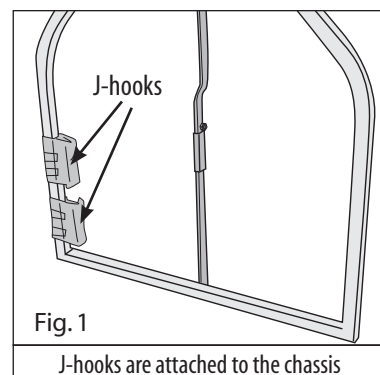

**See reverse side
for parts list.**

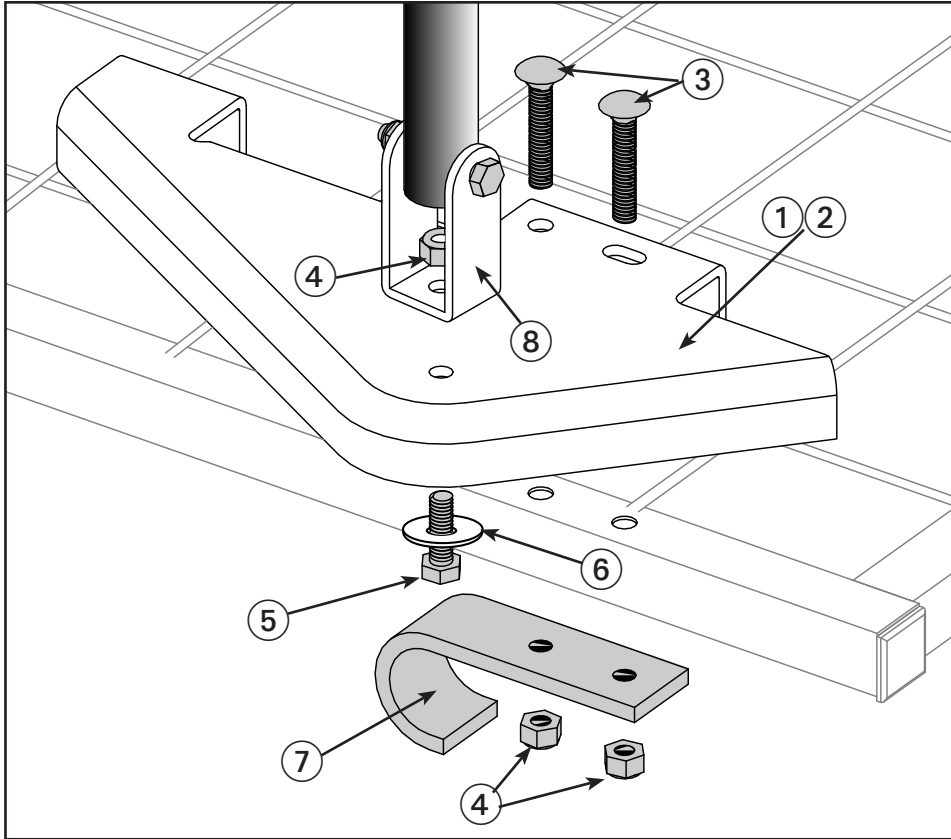

Parts List— Extender Bracket Kit

Key	Item	Qty	Part#
1	Extender Bracket- right	1	01-01-1002
2	Extender Bracket- left	1	01-01-1003
3	5/16-18 x 1.75 Carriage bolt	4	01-01-1034
4	5/16-18 Nylon lock nut	6	01-01-151
5	5/16-18 x 1 Hex Bolt	2	01-01-171
6	5/16 Washer	2	01-01-152

Other Parts Shown

7	J-hook		01-01-025
8	Hinge bracket		01-01-012