

Customer Tools Required: (Fig. 1)

- A socket wrench (3/8 inch drive), with a 6-inch or longer extension bar
- 7/16, 1/2 and 3/4 inch sockets
- 1/2 inch box wrench
- A 7/16 inch box or open wrench
- Phillips head screw driver
- A small flat blade screwdriver (3/16 or 1/4 inch blade width)
- A wooden board, about 3 to 4 inches wide and about 2 feet long, or a 2-foot length of 2 x 4 lumber

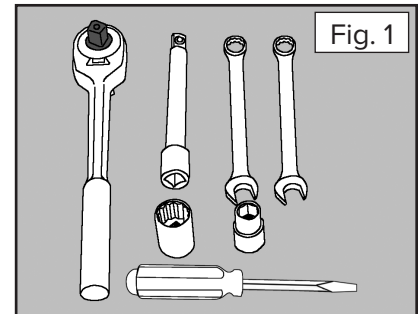

Tools provided (depending on engine type): (Fig. 2)

- 5/16 inch hex-bit socket
- 3/16 inch ball-end hex wrench

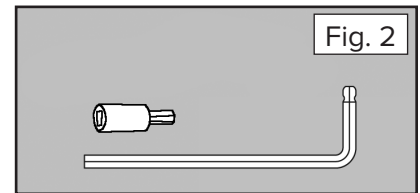

Parts Supplied (depending on engine type): (Fig. 3)

- Impeller bolt with lock washer and heavy washer
- 1/2-10 x 4 inch full threaded bolt (for use as an impeller puller, if needed)
- Shaft key for engine
- Packet of anti-seize grease (for engine shaft) and applicator brush
- Button-head screws set of 2 with lock nuts and washers
- Packet of thread locker
- 6 new rear cover screws and nuts

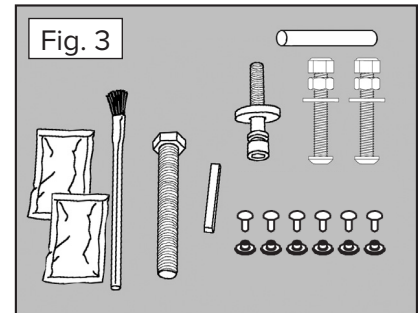

Removing the Blower Housing from the Engine and Engine Frame:

Step 1. Remove the impeller bolt:

IMPORTANT: Disconnect the spark plug wire on the engine.

- **Clean the impeller bolt hex socket thoroughly**, using the small blade screwdriver. You must remove **all dirt and debris** so that the hex-bit socket seats all the way to the bottom of the bolt head. See Fig. 4.
- Place the wooden board or 2x4 inside the blower exit chute to prevent impeller rotation.
- Use the 5/16 hex-bit socket and extension bar to remove the impeller bolt. See Fig. 5.

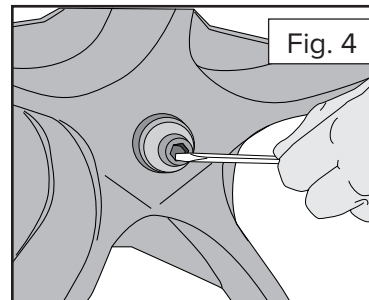

Note: Thoroughly clean all debris from the impeller bolt hex socket before trying to remove the bolt.

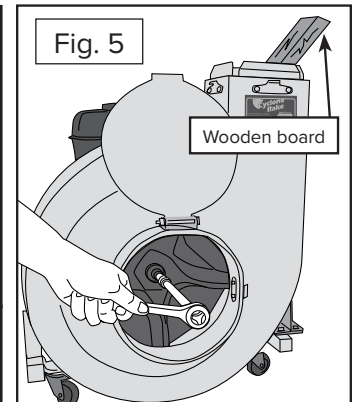

TIP: Because the engine frame is on wheels, it is helpful to clamp one or two short lengths of 2x4 to your work bench so the frame does not roll around. This is especially helpful if you are doing a one-person job.



WARNING: Never use an L-shaped hex wrench to remove the impeller bolt. You will not get enough torque and risk stripping the bolt head. If you strip the bolt head, you will not be able to remove the engine.

Step 2. Remove the blower housing nut which connects the engine to the blower unit.

Note: Save the hardware as you go.

- There are several styles of engine bracket depending on the engine you have. See Fig. 6, Fig. 7 & Fig.8
- Use the 1/2 inch box wrench to remove the nut.

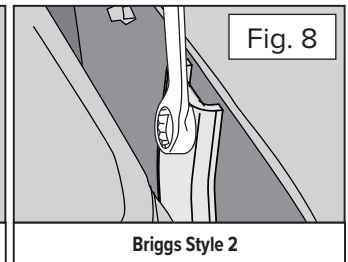
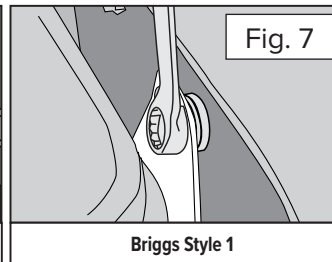
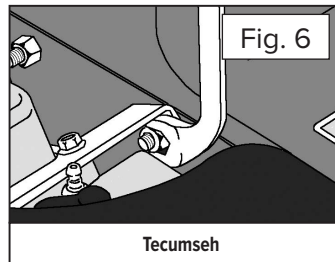

Step 3. Remove the connecting screws

- Using a 1/2 inch socket and wrench remove the two 5/16 nylon lock nuts from each of the 5/16 screws that hold the blower housing to engine frame. See Fig. 9
- Remove the blower support bracket by removing the 5/16-24 fine thread bolts and pop off the small white end cap, remove the threaded plate from the inside of the motor frame. **SAVE** these items for re-assembly. The housing should now be free from the engine frame. See Fig. 10.

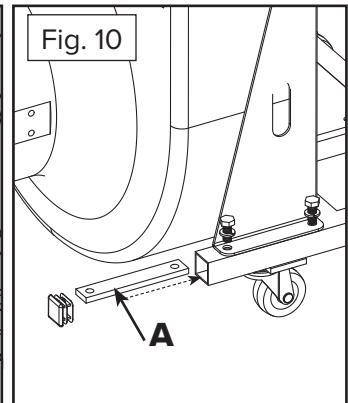
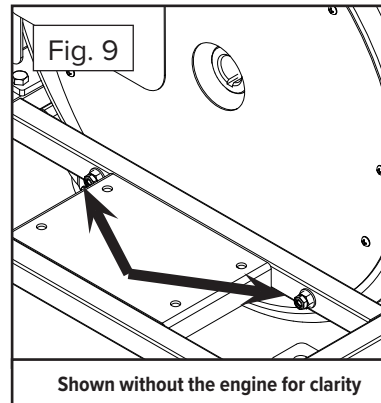

Step 4. Remove the Blower Housing

- Pull the blower housing away from the engine. See Fig. 11. The engine shaft should pull right out of the impeller. If necessary, reach inside the front of the blower to support the impeller while you pull out the engine. The impeller will stay inside the sealed blower housing.
- If the impeller does not pull out easily by hand: 8, 9 & 10 HP engines insert the 3/8 inch steel pin into the hole in the impeller hub, then screw in the 1/2-13 bolt. All others just use the 1/2-13 bolt. Use a 3/4 inch socket to tighten the bolt. It will act as a puller to remove the impeller. See Fig. 12.

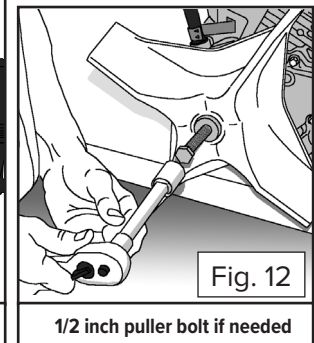
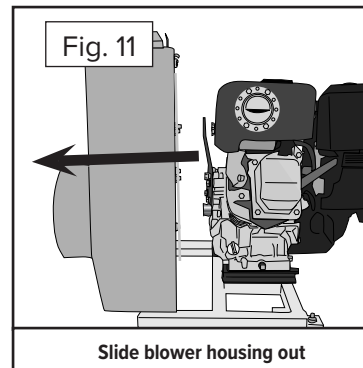

Step 6. Remove the rear cover

- Remove the heat shield and then use the 1/2 inch wrench or socket remove the two remaining nylon lock nuts. See Fig. 13(A).
- Next, remove the 7 special screws holding the rear cover of the blower housing with a Phillips head screw driver. See Fig. 13(B).

NOTE: The Blower Gusset (C) may fall into the housing. If it does, push it back up through the housing.

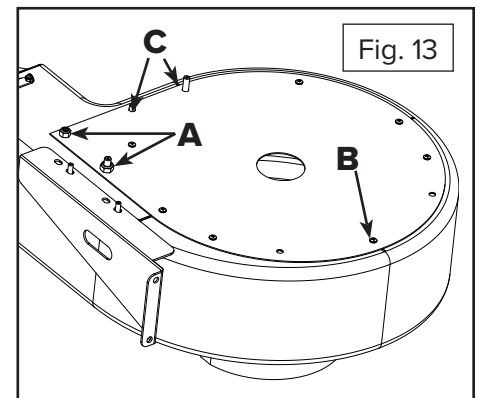

Step 7. Install the new impeller

- Remove the rear cover, take out the old impeller and place the new impeller inside the housing with the flat side facing up.

Reassemble The Blower Housing

Step 1. Replace the rear cover and heat shield

- Replace the rear cover with the 3 larger hole at the top of the blower housing and loosely install 7 **new** special screws and nuts with the thread locker provided. Then go around and tighten all 7 securely. See Fig. 13(B).
- Replace the two 5/16-18 nylon lock nuts. See Fig. 13(A).

NOTE: The Blower Gusset Fig. 13(C) may fall into the housing. If it does, push it back up through the housing.

Attaching Impeller to the Engine

Step 1. Prepare the engine shaft

- Orient the new engine shaft so the key-way is on top. Gently pull the starter cord to rotate the shaft into position.
- Clean the shaft key-way with an old toothbrush or clean rag to remove all dust or grit from the key-way.
- Press the shaft key unto the key-way to seat it completely. You can tap it with a soft object, such as a screwdriver handle, if needed. **Do not tap it with a hammer!** If you nick the key, it will not fit the impeller hub.
- Open the pack of anti-seize grease and squeeze it onto the applicator brush. Coat the shaft and key completely with the grease. See Fig. 14.

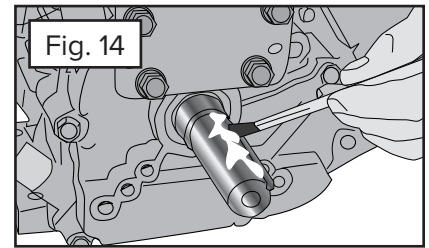

Step 2. Mate the engine and impeller

TIP: This can be done by one person. But it's a lot easier if you have a helper. The helper doesn't need any mechanical skill.

- Using one arm, reach through the front of the blower to grasp the impeller. Hold the impeller so the steel hub passes through the hole in the rear of the blower housing. With the other arm, slide the engine toward the impeller. Orient the slot in the impeller hub with the engine shaft key. Push the engine and impeller together gently so the engine shaft slides into the impeller. See Fig. 15.
- Be sure the hole in the engine bracket passes over the 5/16 inch threaded stud at the top of the blower housing. Then install the nylon lock nut. Tighten the nut. Fig 16.

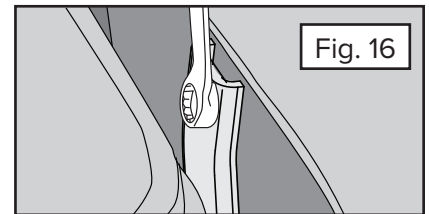
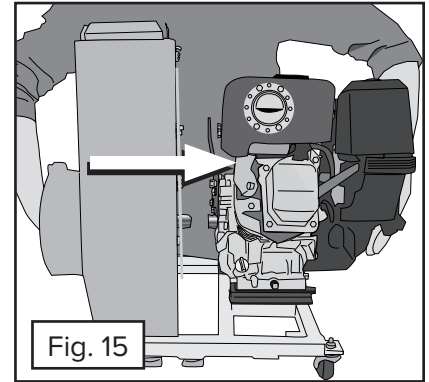

Step 3. Attach the blower housing to the engine frame

- Reach inside the blower housing and push the two button-head screws thru the blower housing and engine frame holes and install two 5/16 inch washers over the screws and attach with two 5/16 nylon lock nuts. Leave the nylon lock nuts finger-tight for now. Fig. 17.
- Attach the support bracket directly to the leg of the motor frame using the threaded plate (A) and two 5/16-24 (fine thread) bolts and lock washers. Hold the threaded plate (A) inside the tube with your finger while starting the bolts. Then tighten the bolts firmly. Fig. 18
- Tap the white plastic tube plug into the open end of the motor frame using a small hammer.
- Using the ball-end hex wrench, reach inside the blower housing and insert the ball end into the button-head screws. Hold the screw heads fixed and tighten the nylon lock nuts on the outside. Tighten firmly. Fig. 26.

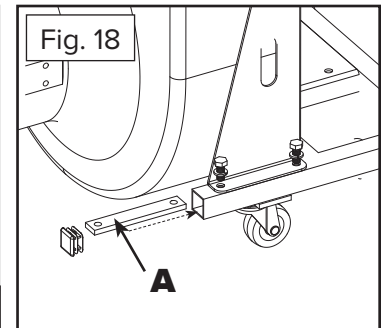
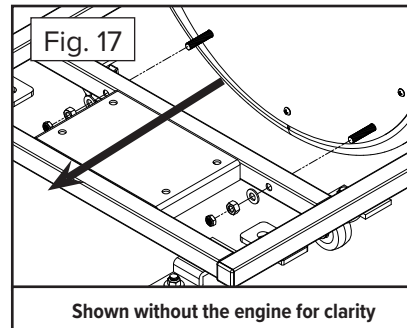

Step 4. Install the Impeller bolt

- Place the wooden board back into the exit chute to prevent impeller rotation. Assemble the fan bolt with the lock washer and heavy washer into the impeller hub. Tighten firmly (approx 40 ft. lbs. of torque) with the ratchet wrench, extender bar and hex-bit socket. See Fig 20

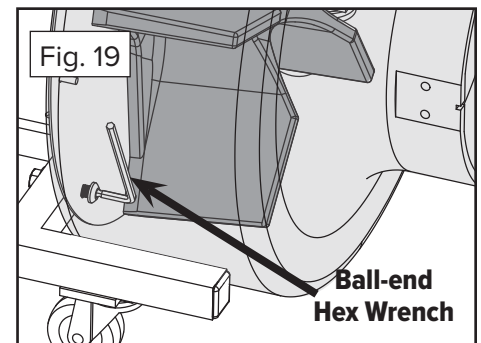

Step 5. Reconnect the spark plug wire.

That's it your done!

