

# Cyclone Power-Lift Unloader Operation & Assembly Instructions



**WOODLAND POWER PRODUCTS, INC.**

72 Acton Street, West Haven, Connecticut 06516

[www.CycloneRake.com](http://www.CycloneRake.com)

©2021, Woodland Power Products, Inc.

**TOLL-FREE 1-(888)-531-RAKE**

01-06-130 S21

# SAFETY WARNING

Always be sure both bag collar latches are open and the dump linkage is attached to the collector frame before using the Power Lifter. Observe the warning label on top of the Power Lifter battery cover. Equipment damage can result if you do not follow these steps.

## WARNING! To Avoid Equipment Damage

Before Lifting:

1. Be sure the Collar Latches are open

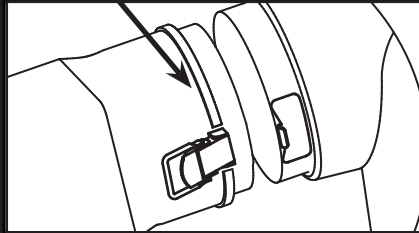

2. Be sure the Dump Linkage is connected to the frame

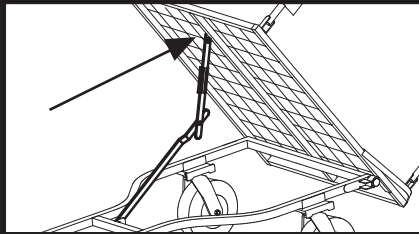

01-01-1701

## IMPORTANT INFORMATION

- **THE LIFTING SPEED HAS BEEN SET TO A GRADUAL RATE FOR YOUR SAFETY** If you have forgotten to release the bag collar latches, or if there is a person or obstacle in the way, you will have time to react before anything gets harmed. The lifting cycle is about 45 seconds.
- **THE UP DIRECTION CONTROL SWITCH IS A MOMENTARY ACTION FOR YOUR SAFETY.** This operation is the same as an electric winch or chain hoist. To stop the lifting, just release the switch.
- **THE LIFTING CYCLE CAN BE STOPPED OR REVERSED AT ANY TIME.** If you are part way up and want to stop or lower the lifter, just click the switch into the neutral or down position.
- **DO NOT ATTEMPT TO WIRE THE POWER LIFTER TO YOUR MOWER BATTERY.** Short circuits, overheated wires and dangerous sparks can result. Use only the Power Lifter's internal battery for electrical power.

## ASSEMBLING THE POWER-LIFT UNLOADER

See Section 2, Assembling the Power-Lift Unloader, on page 7. Then return here for mounting and operating instructions.

### MOUNTING THE POWER LIFTER TO YOUR CYCLONE RAKE

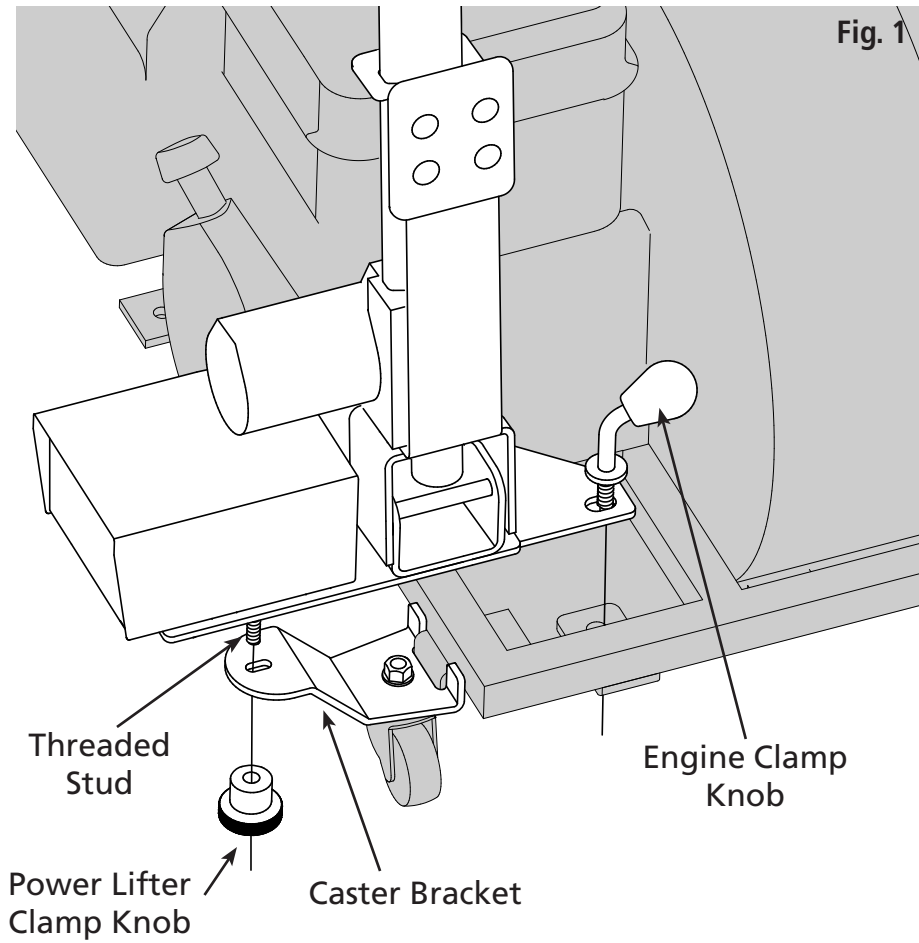

1. Set up your Cyclone Rake and mount the engine unit. Leave off the Engine Clamp Knob closest to the collector frame.
2. Place the Power Lifter over the engine frame as shown in Figure 1. Be sure the Threaded Stud under the base plate passes through the hole in the Caster Bracket.
3. Tighten the Engine Clamp Knob and screw on the Power Lifter Clamp Knob from below as shown.
4. Lift the collector frame and hook the free end of the lifter cable through the Collector Bracket as shown in Figure 2. Then lower the collector frame.

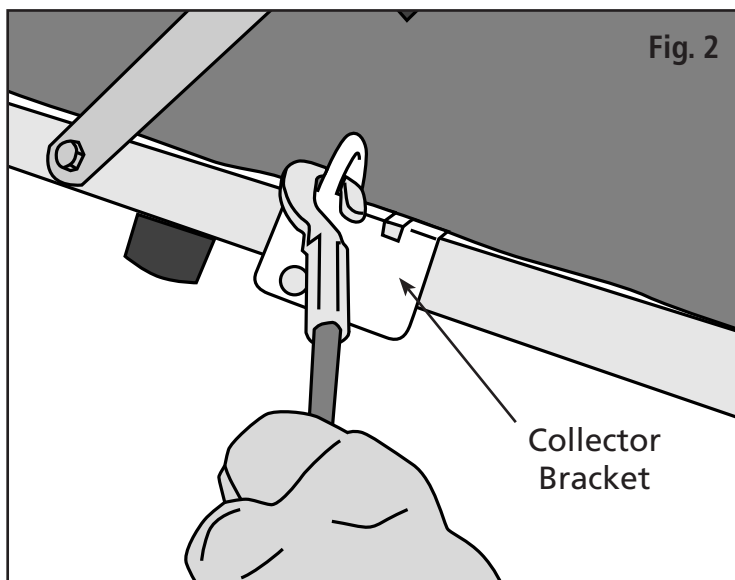

# USING THE POWER-LIFT UNLOADER

## General information

- A fully-charged battery in good condition will provide power for about 25 to 40 loads of Cyclone Rake debris. This is many times a typical daily use.
- During active season, charge the battery overnight after each day's use. See the yellow label on side of battery cover for additional information on proper battery care. Read especially the label information on long-term storage during off-season periods.
- Always press the Charger Socket rubber cap closed after charging. This prevents dirt, rain and dust from entering the socket.
- During cold weather all batteries produce less energy. So expect somewhat fewer loads if you are operating in cold or sub-freezing weather.
- If possible, leave the charger connected to power during long-term storage. This will extend battery life because it provides a conditioning trickle charge to the battery. The charger draws only about ½ watt, which costs about 50¢ per year to run. If you can't store the Power Lifter long-term near an electrical source, then bring it to a power source and charge it overnight about once every two months.
- The battery is a type known as a "deep cycle" storage battery. It is not intended for engine starting. Do not use it for that purpose, as this can cause permanent harm to the battery.

## MAINTENANCE

The Power Lifter is maintenance-free except for charging the battery. No lubrication is necessary.

## STORAGE

All electrical equipment should be stored in a dry, protected area. Do not leave the Power Lifter outdoors exposed to weather. Do not store outdoors under a tarp for extended periods. Salt air and salt water are extremely corrosive to electrical components. If you live near the seashore, store the Power Lifter inside the house or in a properly enclosed storage building.

# CYCLONE POWER-LIFT UNLOADER

Cyclone Master Hand Control

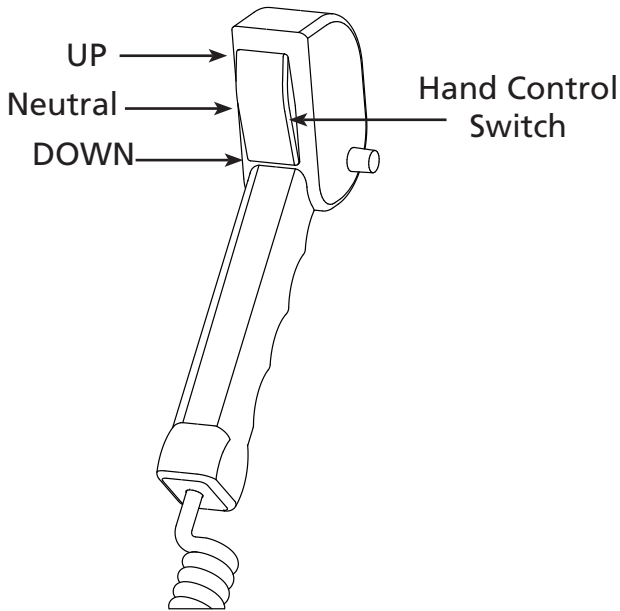

**Hand Control Switch** has three positions: "UP" (momentary), "NEUTRAL" (detent) and "DOWN" (momentary). You can stop the up or down cycle at any point. The motor will shut off at the end of travel, either up or down.

Front Panel

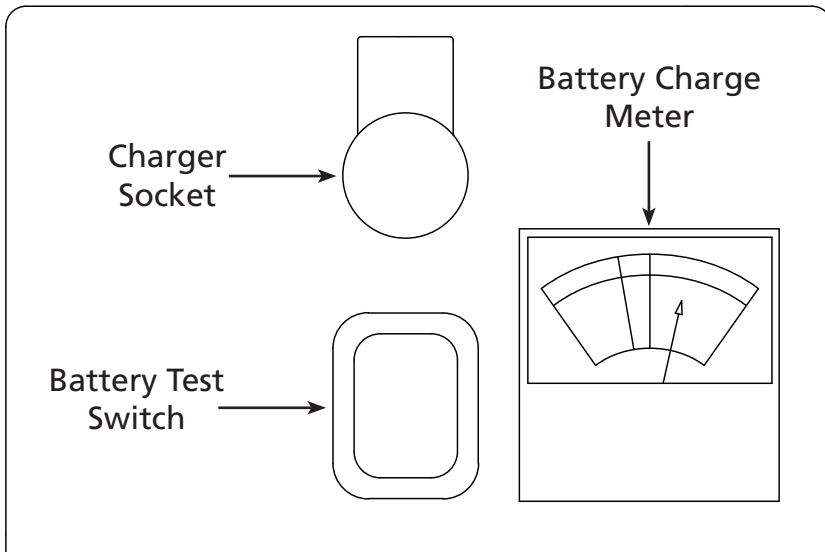

**Charger Socket** is located under the rubber cap. **Always press the rubber cap closed after charging.** This prevents rain, mud or dust from entering the socket.

**Battery Charge Meter** shows charge condition of the battery. The meter is inactive until you press the "TEST" switch. This prevents the meter from discharging the battery when the Power Lifter is in storage.

**Battery Test Switch:** press to activate the battery charge meter.

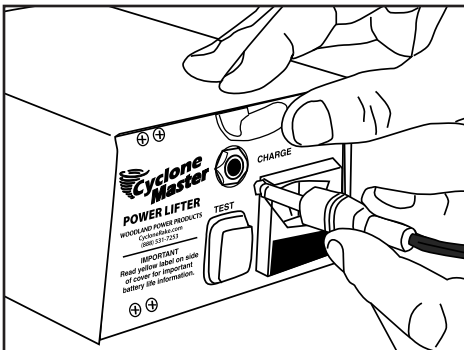

Lift rubber cap to charge

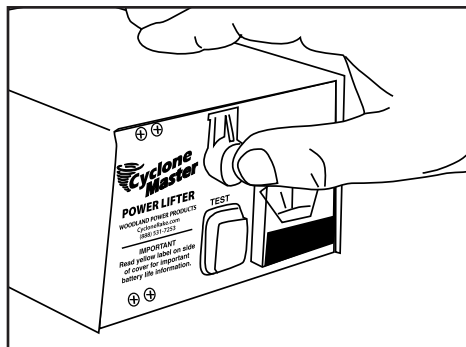

Press cap closed after charging

## Section 2

# Power Lifter Assembly Instructions

### MOUNT THE LINEAR ACTUATOR AND PULLEY ASSEMBLY

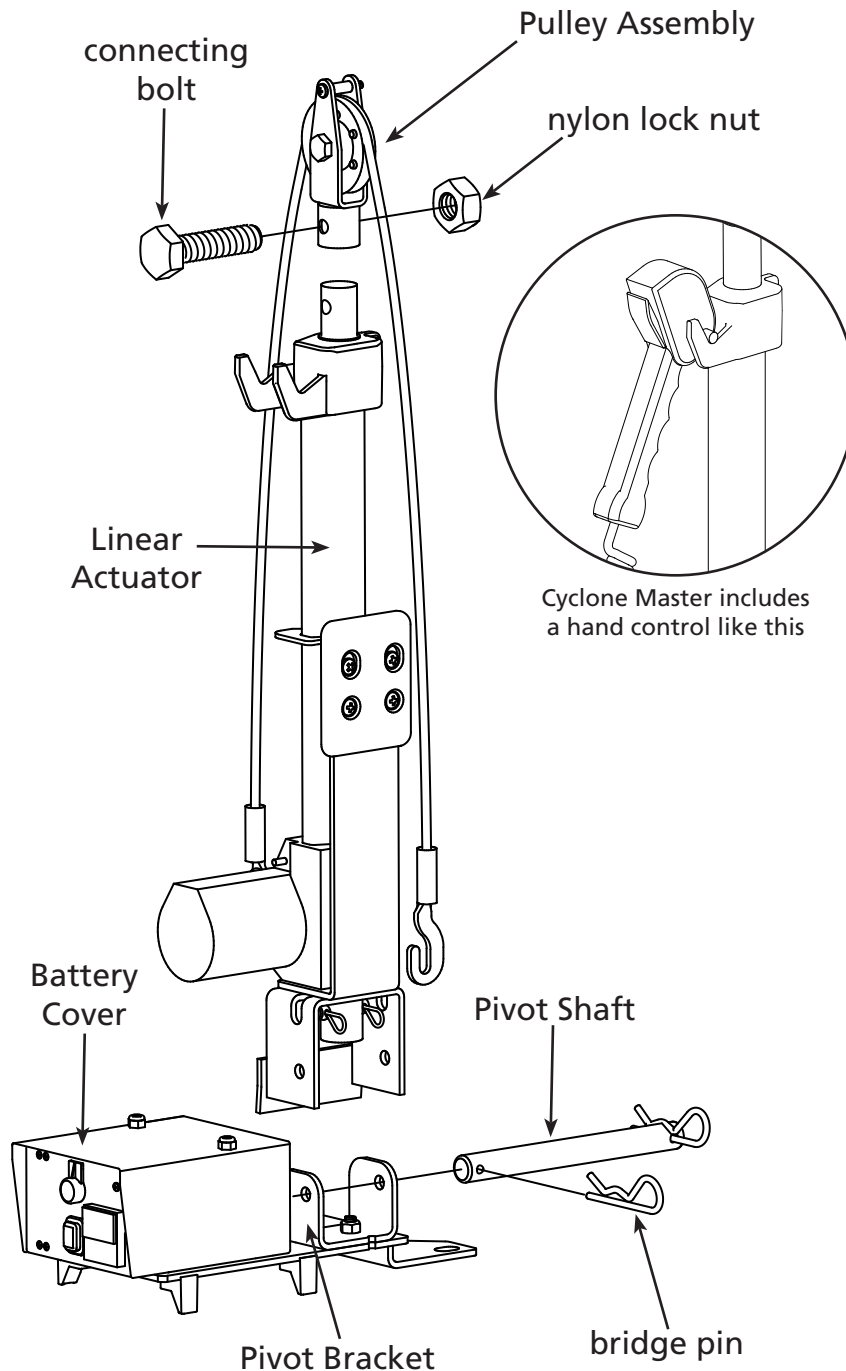

1. Remove the bridge pin under the Actuator motor and slide out the Pivot Shaft.
2. Position the Linear Actuator as shown to align the holes, then slide the Pivot Shaft back in and replace the bridge pin.

**Note:** The motor should be located above the Battery Cover. The legs of the Linear Actuator should be outside the legs of the Pivot Bracket.

3. Attach the Pulley Assembly and tighten the connecting bolt and nylon lock nut securely.

#### Tool Required

Phillips Screwdriver  
7/16 Wrench or Deep-well Socket  
9/16 Wrench or Sockets  
14 mm Wrench or Socket

## MOUNT THE RETURN SPRING

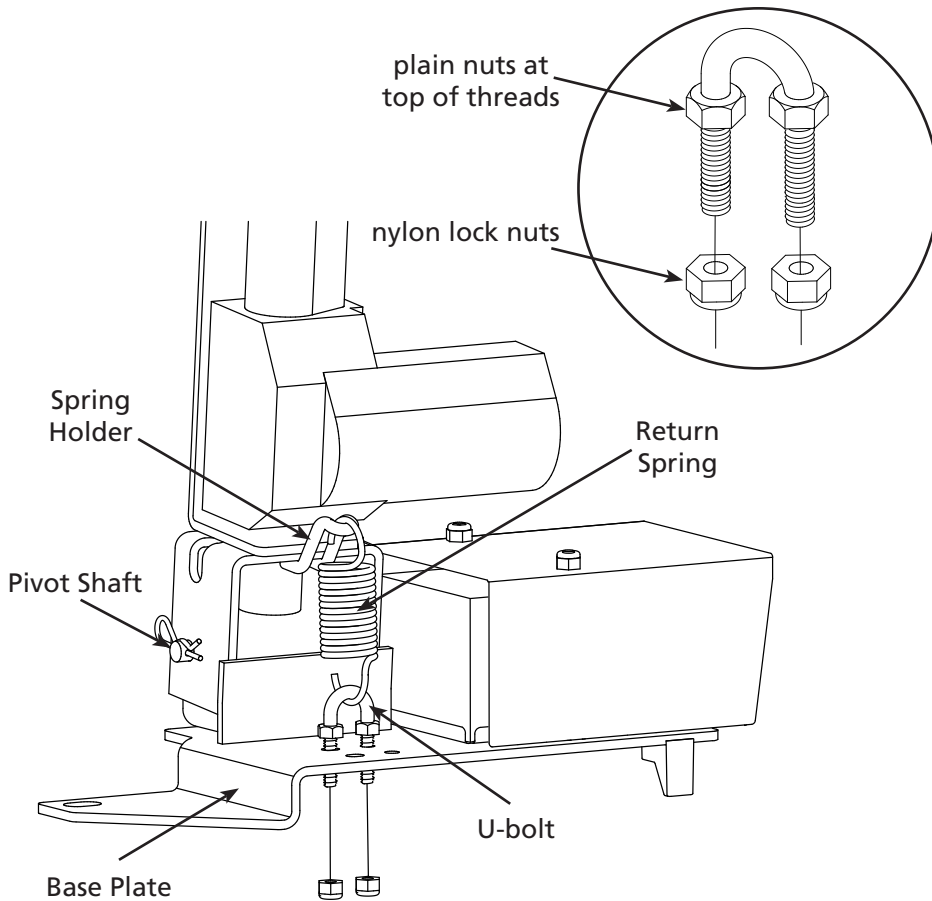

1. Hook one end of the Return Spring over the Spring Holder and the other end through the U-bolt. Be sure the U-bolt has two  $\frac{1}{4}$ -20 plain nuts which are screwed all the way to the top of the U-bolt threads, as shown in the inset illustration.
2. Place the U-bolt legs through the pair of holes **closest to the Pivot Shaft**. Tighten the two nylon lock nuts to draw the spring all the way down. It is best to tighten each nut one turn at a time to get an even draw. Continue tightening until the two  $\frac{1}{4}$ -20 plain nuts are firmly tightened against the top of the Base Plate.

## ATTACH THE CABLE EYE

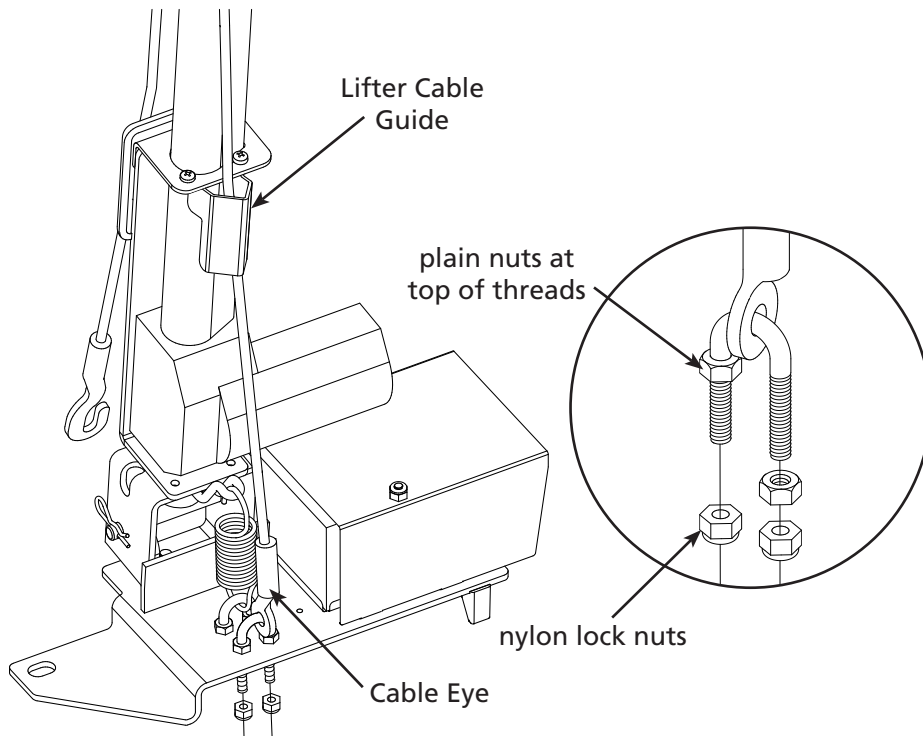

1. Slip the Cable Eye through the Lifter Cable Guide as shown.
2. Place the second U-bolt through the Cable Eye, as shown in the inset drawing. Then screw the two plain  $\frac{1}{4}$ -20 nuts all the way to the top of the threads so that the Cable Eye is trapped between the two nuts.
3. Place the U-bolt through the second set of holes in the Base Plate and tighten the two nylon lock nuts all the way down.

## CONNECT THE ELECTRIC WIRES

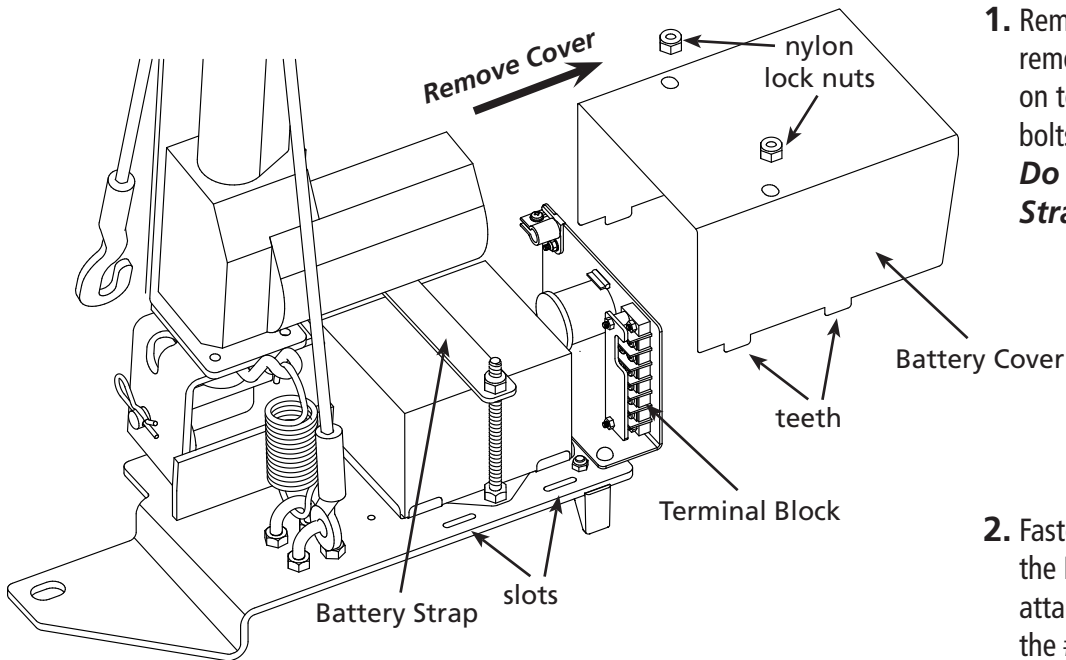

1. Remove the Battery Cover by removing the two nylon lock nuts on top. Lift the cover up over the bolts and slide it off as shown. **Do not loosen the Battery Strap inside the cover.**

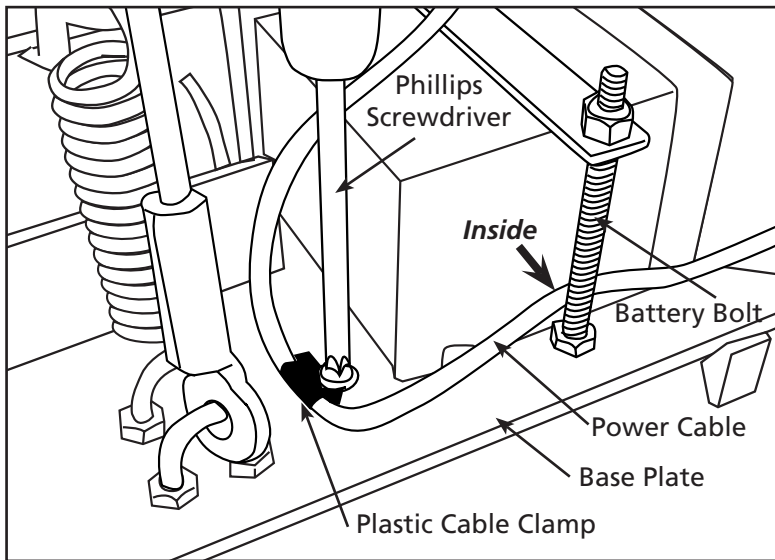

2. Fasten the Plastic Cable Clamp to the Base Plate with the #10 screw attached to the clamp. Then attach the #10 nylon lock nut to the bottom of the screw which projects through the Base Plate. Tighten the nylon lock nut by holding the screw with a Phillips Screwdriver while tightening the nylon lock nut.

3. Be sure the Power Cable passes inside the Battery Bolt, between the bolt and the battery as shown.

4. Loosen the two exposed terminal screws on the Terminal Block about 2 turns each. Slide the Fork Connectors under the screws and tighten. **The white wire must be connected to the white terminal and the green wire to the green terminal.**

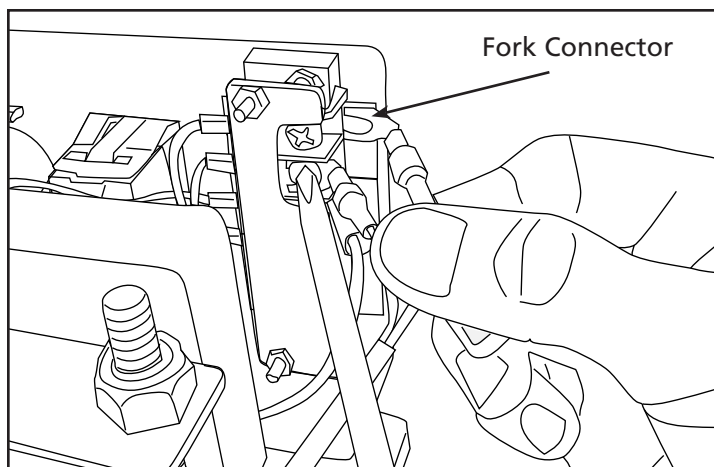

5. Bend the Fork Connectors slightly inward to allow wiring to fit inside Battery Cover.

6. Replace the Battery Cover using the two nylon lock nuts. **Be sure the teeth on the Battery Cover are seated in the slots of the Base Plate.**



## ATTACH THE COLLECTOR BRACKET TO THE COLLECTOR FRAME

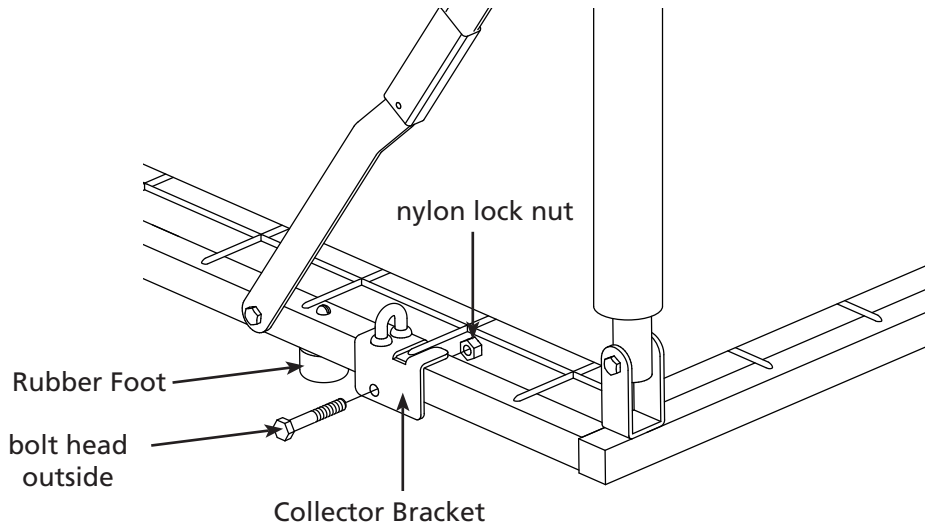

1. Place the Collector Bracket on the collector frame as shown, and firmly tighten the bolt and nylon lock nut.

**Note:** *The Collector Bracket must be placed exactly as shown in the drawing.* It must straddle the collector frame wire nearest to the Rubber Foot as shown. The bolt head must be on the outside as shown.

## ATTACH THE CASTER BRACKET TO THE ENGINE FRAME

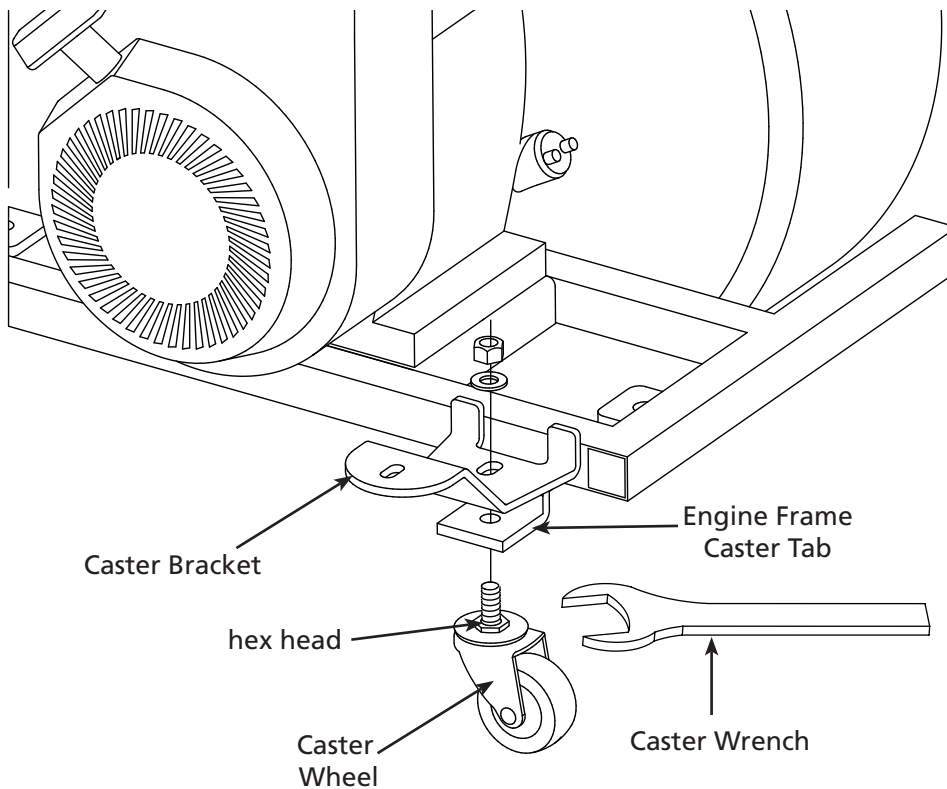

1. Set up your Cyclone Rake and mount the engine unit on the chassis.
2. Remove the top nut from the engine frame Caster Wheel, located to the right of the engine recoil starter as shown.

**Note:** If the caster stem rotates when loosening the nut, use the flat Caster Wrench provided to hold the caster from below. The caster has a hex head below the threaded stem. The wrench has two sizes. Use the one which fits your casters.

3. Place the Power Lifter Caster Bracket on top of the Engine Frame Caster Tab. The two ears on the Caster Bracket must be located against the engine frame as shown. Then re-install the Caster Wheel and nut. Use the Caster Wrench, if needed, to hold the caster when tightening the caster nut.

**Congratulations! The assembly is complete**  
Now turn to page 3 to learn how to mount and use your  
Power-Lift Unloader.

# CYCLONE POWER LIFT UNLOADER PARTS LIST

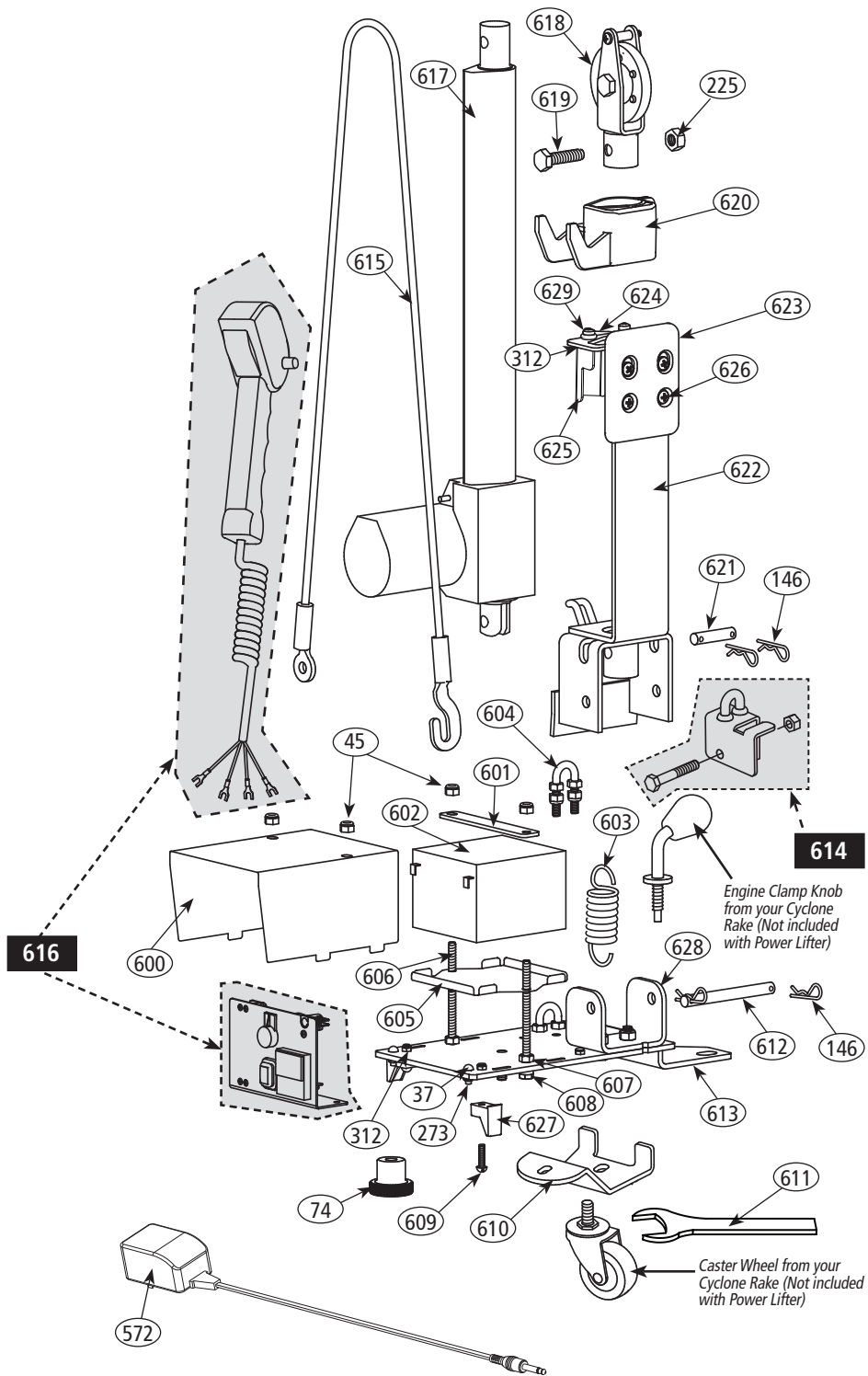

37	10-24 x 1/2 in. Screw	01-01-173
45	1/4-20 Nylon lock nut	01-01-157
74	Clamp knob	01-01-291
146	Bridge pin, 42 mm	01-01-473
225	3/8 Nylon lock nut	01-01-240
273	10-24 Low height nylon lock nut	01-01-199
312	M5 Nylon lock nut, 0.8 mm pitch	01-01-1122
572	Charger	01-01-1504
600	Battery cover	01-01-1538
601	Battery strap	01-01-1552
602	Battery	01-01-1539
603	Return spring	01-01-1545
604	U-bolt with nuts	01-02-554
605	Battery tray	01-01-1537
606	1/4-20 x 4-in. Full thread bolt	01-01-1536
607	1/4-20 Hex nut	01-01-1551
608	Spacer, battery bolt	01-01-1632
609	M5 x 20 mm Screw	01-01-1489
610	Caster bracket	01-01-1540
611	Caster wrench	01-01-1996
612	Pivot shaft	01-01-1535
613	Base plate with stud	01-02-536
614	Collector bracket	01-03-404
615	Lifter cable assembly	01-02-543
616	Control panel assembly & Hand control	01-03-540
617	Linear actuator	01-01-1612
618	Pulley assembly complete	01-03-395
619	3/8-16 x 1.75 in. Full thread bolt	01-01-1668
620	Hand control holder	01-02-555
621	Holding pin	01-01-1592
622	Actuator pivot assembly	01-02-542
623	Wear plate	01-01-1627
624	Actuator brace	01-01-1622
625	Cable shield	01-01-2167
626	M6 x 16 mm Pan head screw, 1.0 mm pitch	01-01-1642
627	Base plate foot	01-01-1548
628	Pivot bracket	01-01-1510
629	M5 x 16 mm Screw, 0.8 mm pitch	01-01-1641
645	Spare parts kit (not shown)	01-02-557