

Installation Instructions

These instructions will guide you through the installation of the Cyclone Rake Exhaust Deflector.

Parts Included:

Exhaust Deflector: Part# 05-02-010

Tools You Will Need:

5/16" Nut driver or Socket wrench with 5/16" socket

Note: This installation reuses the 3 screws(A) that secure the original exhaust deflector.

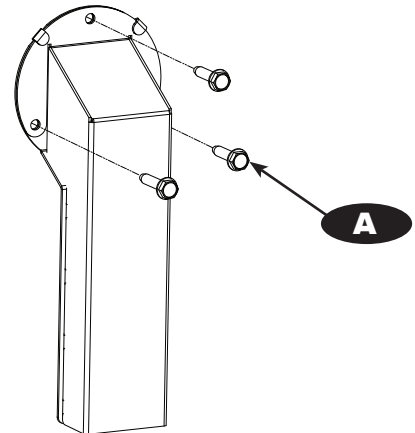

1. Remove the three screws securing the factory installed exhaust deflector. (A). Save the screws for later. (Fig. 1a)

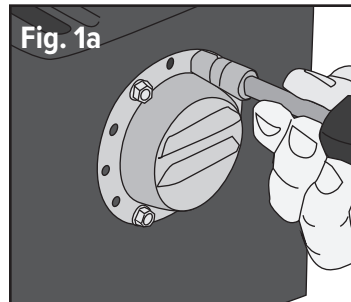

Remove exhaust screws.

2a. Manual Start Engines: Line up the Exhaust Deflector so that it points about 30 degrees from vertical. Rotate the Spark Arrestor (Fig. 1b) so its 3 holes match with screw positions (A) on Exhaust Deflector. Install the 3 screws you removed earlier as shown in Fig. 2a.

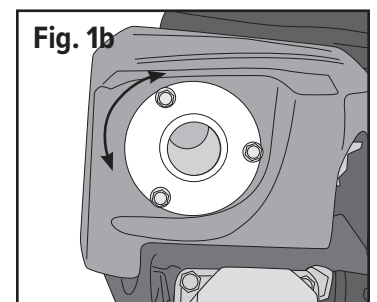

Rotate the Spark Arrestor to match the desired angle of the Exhaust Deflector

2b. Electric Start Start Engines: Line up the Exhaust Deflector so it points about 60 degrees from vertical. To ensure the exhaust stream does not hit the battery. Rotate the Spark Arrestor (Fig. 1b) so its 3 holes match with screw positions (A) on Exhaust Deflector. Install the 3 screws you removed earlier as shown in Fig. 2b.

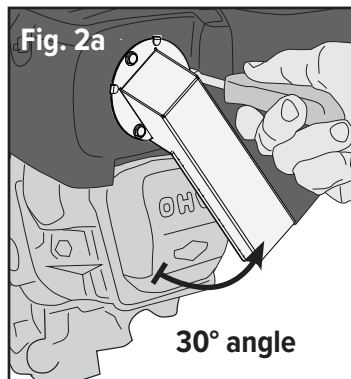

Manual Start Engines: Position deflector at 30° and reinstall screws

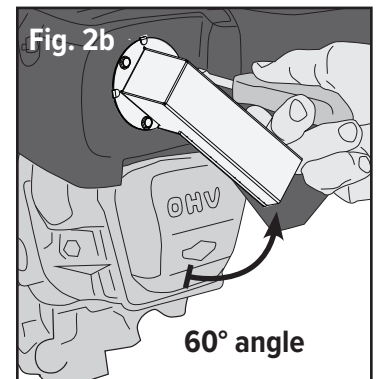

Electric Start Engines: Position deflector at 60° and reinstall screws

NOTE: Do not overtighten. The screws do not need to sit flush.

WARNING: Never use the Exhaust Deflector as a handle for lifting or moving the engine. You will damage the muffler housing. Only use the motor handles for lifting or moving the engine.