

- 1.** Place collector bag in the upright position – with the top brace removed.

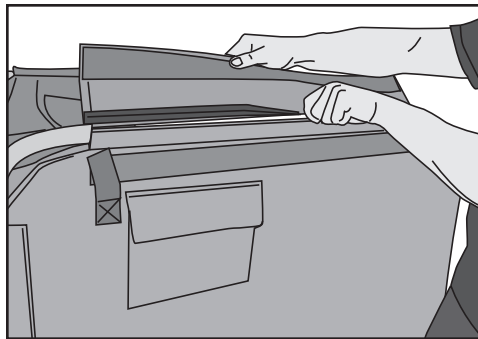

- 2.** Open the Velcro strip, or top zipper that secures your collector bag to the top of the side tube.

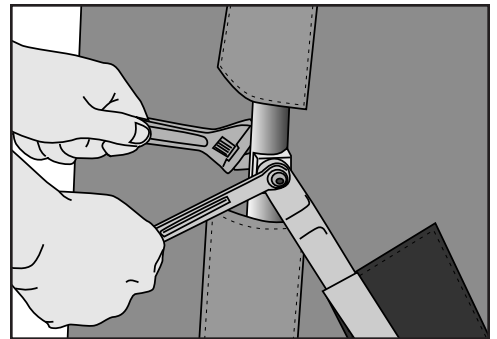

- 3.** With the side link locked in place, disconnect the pivot bolt and lower the side link out of the way.

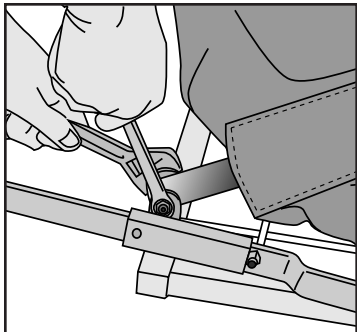

- 4.** Disconnect the front and rear hinge bolts from the ends of the aluminum side tube.



- 5.** Slide the side tube out of the collector bag.
6. If replacing both side tubes, repeat steps 2-5 on the opposite side of the bag.

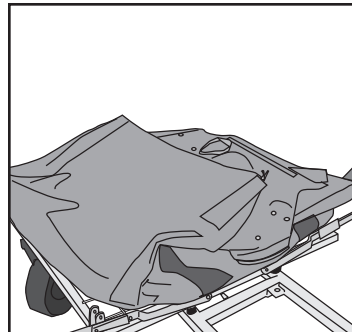

- 7.** To install the new side tube, start with the collector bag flat on the collector frame.

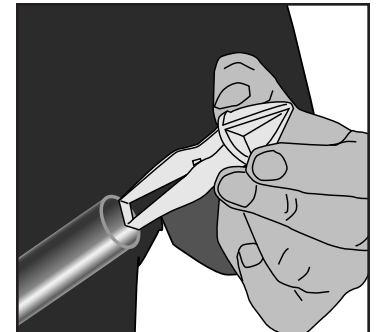

- 8.** Place the plastic side tube insertion plugs into both ends of the new aluminum side tube.

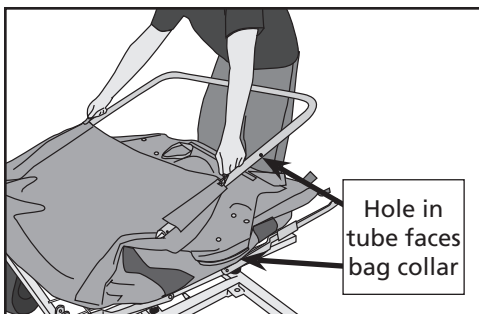

- 9.** Locate the hole in the side tube for the side link installation and place the hole towards the front of the collector.
10. Slide the side tube into the pockets on the collector bag. Slide the tube evenly for least resistance.

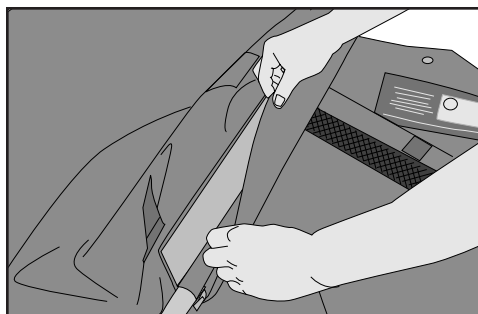

- 11.** When side tube is completely inserted, remove the plugs and secure the upper zipper or Velcro flap.
12. For collector bags with Velcro strips, be sure to align the strips properly. The Velcro strap should completely cover the Velcro strip on the collector bag.

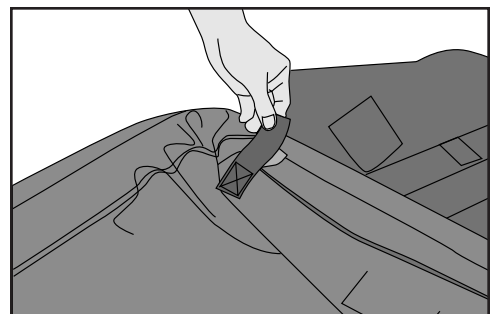

- 13.** Close the Velcro tabs at the ends.
14. If replacing both side tubes, repeat steps 8-13 now.

See reverse side for important instructions on replacing bolts.

Bolt Assembly Instructions

Follow the instructions below to reinstall the side tube and side link assemblies. When reassembling the side tubes, it is important that the bolt heads be placed on the inside of the frame (facing the collector bag). This assembly requires nylon lock nuts. Do not substitute ordinary nuts. If your machine is equipped with plastic wear blocks (A), follow the "Style 1" instructions. Otherwise, follow "Style 2".

INSTALL THE SIDE TUBE

STYLE 1

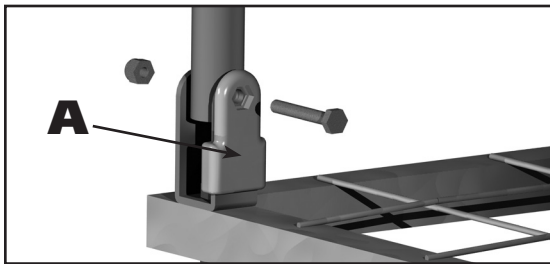

15. If your machine is equipped with white plastic wear blocks (A), be sure bolts are installed with heads on the inside, facing the collector bag.

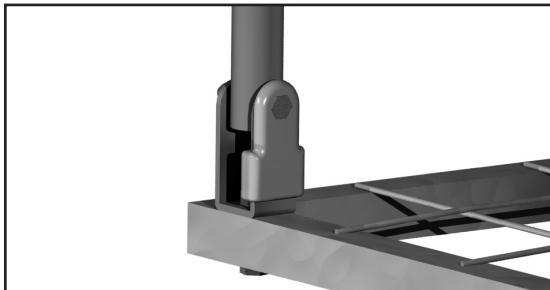

16. Bolt heads must sit flush with plastic wear block.

STYLE 2

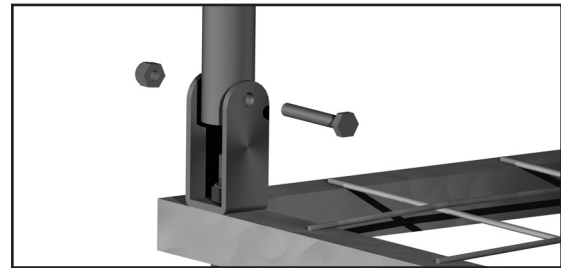

15. If your machine is not equipped with plastic wear blocks, install bolts with heads on the inside, as shown.

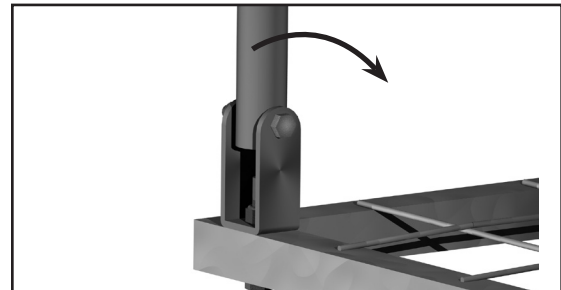

16. Do not over-tighten the bolts. Tube must be free to rotate in the hinge bracket.

INSTALL THE PIVOT BOLT

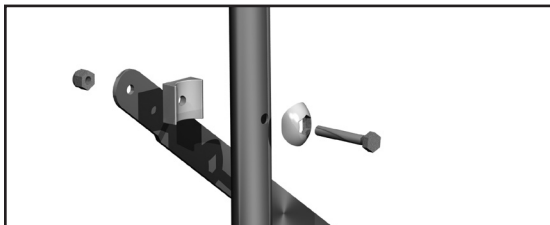

17. If your machine is equipped with one or more plastic spacers on the side tubes, install bolts as shown, with the bolt heads on the inside.

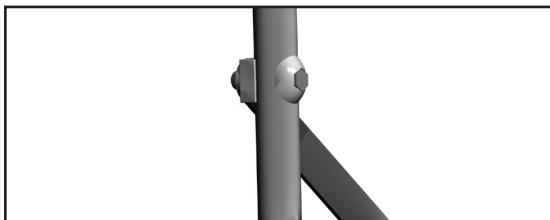

18. Finished installation with plastic spacers looks like this.

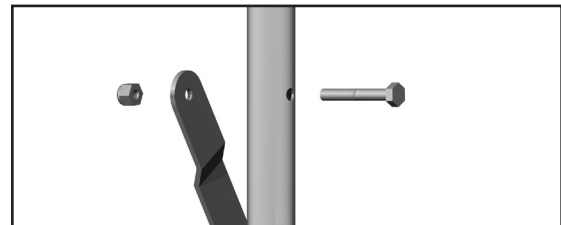

17. If your machine is not equipped with plastic spacers, install bolts with heads on the inside.

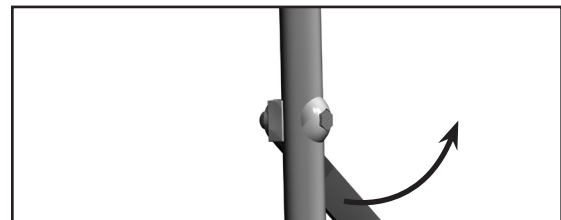

18. Finished installation without plastic spacers looks like this. Do not over-tighten bolts. The side link must be free to rotate against the side tubes.

19. If replacing both side tubes, repeat steps 15 to 18 for the other side tube.

That's it your done!