

Assembly and Installation

This Mower Deck Adapter (MDA) is designed to work with several mower deck designs. The MDA does not need an airtight fit to deliver exceptional vacuum performance. It simply needs to be installed in front of the opening on the mower deck. Follow the instructions below to install.

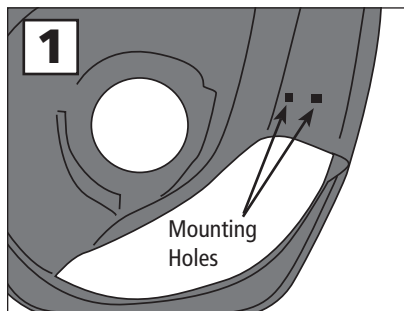

1. Remove the hinged grass deflector from your mower deck to expose the deck opening and the two mounting holes.

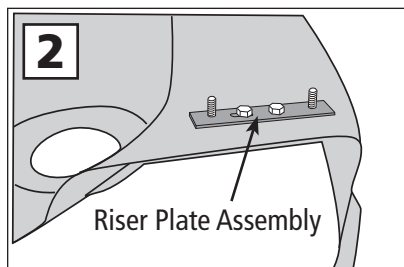

2. Attach the Riser Plate to the mower deck using the two 5/16 x 3/4-inch bolts provided. Install with washers and lock nuts then tighten.

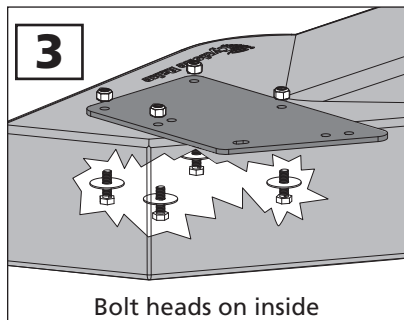

3. Install the four 5/16 x 1-inch bolts, each with a 5/16 fender washer, up through the inside of the boot and the boot plate. Secure with the 5/16 nylon lock nuts.

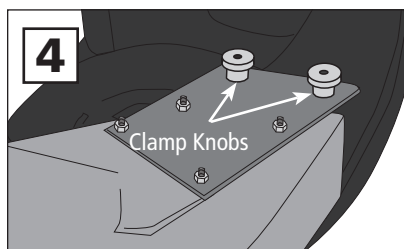

4. Position the MDA over the opening of the mower deck. Place the Boot Plate over the Riser Plate bolts. Then, place one rubber washer on each stud. Spin on the Boot Plate Clamp Knobs.

5. Connect the hose collar onto the MDA with the latches and cut the hose to length as described in your owner's manual if needed.

That's it you're finished!

Safety Note:
If you remove the Mower Deck Adapter later, you MUST re-install the grass deflector.

COMPONENT LIST MDA-W

PART NO.	NAME	QTY
01-02-102	Special Boot w/strikes	1
05-02-102	Special Boot w/strikes - XL	1
06-02-102	Special Boot w/strikes - Z-10	1
01-01-151	5/16-18 Nylon lock nut	6
01-01-152	5/16 Washer	2
01-01-166	10-24 T-nut	4
01-01-171	5/16-18 x 1 Bolt	4
01-01-175	5/16 Fender washer	4
01-01-201	5/16-18 x 3/4 Bolt	2
01-01-291	Clamp Knob - Boot Plate	2
01-01-365	Warning Label	1
01-02-454	Riser Plate	1
01-01-809	S42-Boot Plate	1
01-01-1990	Rubber washer	2
01-02-564	Standard strike w/hardware	3
01-02-142	8" x 8" Collar complete - green	1
01-02-486	7" x 8" Collar complete	1
05-02-080	8" x 8" Collar complete - yellow	1
06-02-080	10" x 10" Collar complete	1
08-02-080	8" x 6" Collar complete	1

