

## Assembly and Installation

This Mower Deck Adapter (MDA) is designed to work with several mower deck designs. The MDA does not need an airtight fit to deliver exceptional vacuum performance. It simply needs to be installed in front of the opening on the mower deck. Follow the instructions below to install.

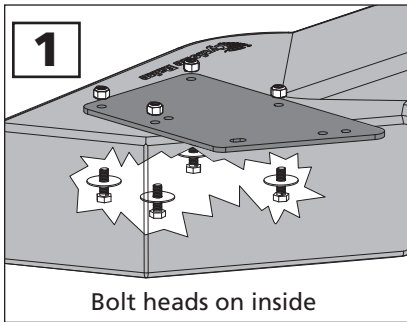

1. Install the four 5/16 x 1-inch bolts, each with a 5/16 fender washer, up through the inside of the boot and the boot plate. Secure with the 5/16 nylon lock nuts.

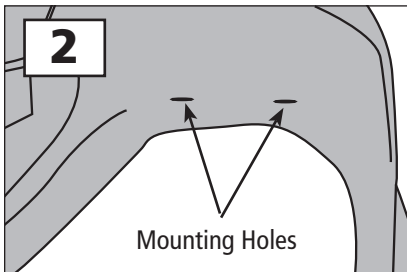

2. Remove the hinged grass deflector shield and hinge bracket from your mower deck to expose the deck opening and the two mounting holes.

**NOTE:** In some cases you may need to drill the mounting holes. Use the Boot Plate as a guide and drill two 5/16 holes.

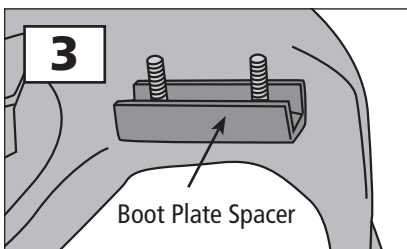

3. Push the two 5/16 x 1.75-inch bolts up through the bottom of the mower deck and screw them into the threaded holes in the "U" shaped Boot Plate Spacer. Tighten firmly with a wrench. You will now have two threaded studs protruding from your mower deck.

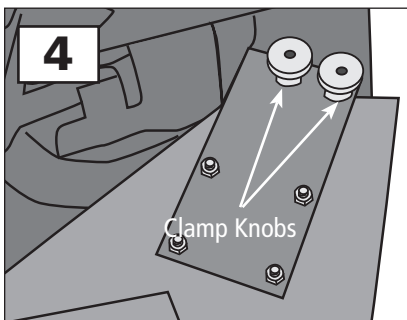

4. Place the MDA over the threaded studs. Place one rubber washer on each stud. Spin on the Boot Plate Clamp Knobs over the mounting bolts.

5. Connect the hose collar onto the MDA with the latches and cut the hose to length as described in your owner's manual if needed. That's it you're finished!

### Safety Note:

**If you remove the Mower Deck Adapter later, you MUST re-install the grass deflector.**

### COMPONENT LIST

#### MDA-M/N

PART NO.	NAME	QTY
01-02-102	Special Boot w/strikes	1
05-02-102	Special Boot w/strikes - XL	1
06-02-102	Special Boot w/strikes - Z-10	1
01-01-151	5/16-18 Nylon lock nut	4
01-01-152	5/16 Washer	2
01-01-171	5/16-18 x 1 Bolt	4
01-01-175	5/16 Fender washer	4
01-01-291	Clamp Knob - Boot Plate	2
01-01-365	Warning Label	1
01-01-841	M40-Boot Plate	1
01-01-842	Boot Plate Spacer	1
01-01-1131	5/16-18 x 1.75 Full-thread bolt	2
01-01-1990	Rubber washer	2
01-02-564	Standard strike w/hardware	3
01-02-142	8" x 8" Collar complete - green	1
01-02-486	7" x 8" Collar complete	1
05-02-080	8" x 8" Collar complete - yellow	1
06-02-080	10" x 10" Collar complete	1
08-02-080	8" x 6" Collar complete	1

