

Assembly and Installation

This Mower Deck Adapter (MDA) is designed to work with several mower deck designs. The MDA does not need an airtight fit to deliver exceptional vacuum performance. It simply needs to be installed in front of the opening on the mower deck. Follow the instructions below to install.



1. Remove the hinged grass deflector from your mower deck to expose the deck opening. (Fig. 1) Also remove the two serrated washers and carriage bolts from the mower deck. (A)

Safety Note: If you remove the Mower Deck Adapter later, you **MUST** re-install the grass deflector.

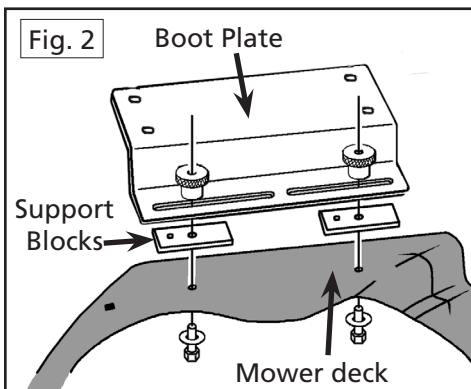

2. Push the two 5/16 x 1.5 inch full-thread bolts up through the bottom of the mower deck and screw them into the threaded holes in the small rectangular Support Blocks. Position the Boot Plate over the mower deck mounting bolts and secure with the two Boot Plate Clamp Knobs. (Fig 2).

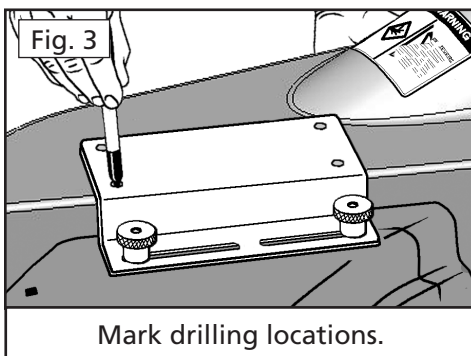

4. Hold the cut boot snugly against the lower surface of the Boot Plate and also up against the deck opening, slightly overlapping the mower deck edges. While holding the boot in place mark the four bolt hole positions for the Boot Plate with a marker pen. Loosen the Clamp Knobs and remove the Boot Plate from your mower deck (Fig. 3)

5. Place the boot on a stable surface. Using the Boot Plate as a template, drill four 5/16" holes through the boot in the four bolt positions. The best way is to first drill one hole, and then drop a bolt through the hole temporarily to keep the plate lined up. Repeat the process until all holes have been drilled.

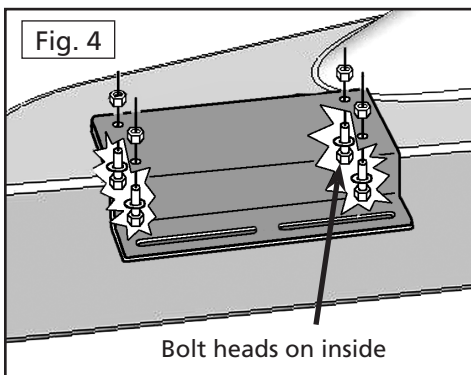

6. Install the 5/16 x 1" bolts, each with a washer, up through the inside of the boot. Place the boot plate on top and secure each bolt with a 5/16 lock nut (fig 4). Tighten firmly.

7. Install the MDA assembly on the mower deck. Place one rubber washer on each stud. Spin on the Boot Plate Clamp Knobs (fig 5).

8. Attach the hose collar onto the MDA with the latches. Cut the hose to length as described in your Cyclone Rake Owner's Manual if needed.



That's it you're finished

COMPONENT LIST

042-MDA

PART NO.	NAME	QTY
01-02-145	Short Boot w/strikes	1
05-02-145	Short Boot w/strikes - XL	1
06-02-145	Short Boot w/strikes - Z-10	1
01-01-069	Standard Boot Plate	1
01-01-150	5/16-18 x 1.5 Full thread bolt	2
01-01-151	5/16 - 18 Nylon lock nut	4
01-01-152	5/16 Washer - type A series W	6
01-01-171	5/16-18 x 1 Hex bolt	4
01-01-291	Clamp Knob - Boot Plate	2
01-01-441	Support Block	2
01-02-142	8" x 8" Collar complete - green	1
01-02-486	7" x 8" Collar complete	1
01-02-125	Support block, 1.5 bolt & washer	2
01-02-564	Standard strike w/hardware	3
01-02-142	8" x 8" Collar complete - green	1
01-02-486	7" x 8" Collar complete	1
05-02-080	8" x 8" Collar complete - yellow	1
06-02-080	10" x 10" Collar complete	1
08-02-080	8" x 6" Collar complete	1

