

Assembly and Installation

This Mower Deck Adapter (MDA) is designed to work with several mower deck designs. The MDA does not need an airtight fit to deliver exceptional vacuum performance. It simply needs to be installed in front of the opening on the mower deck. Follow the instructions below to install.

Safety Note:
If you remove the Mower Deck Adapter later, you MUST re-install the grass deflector.

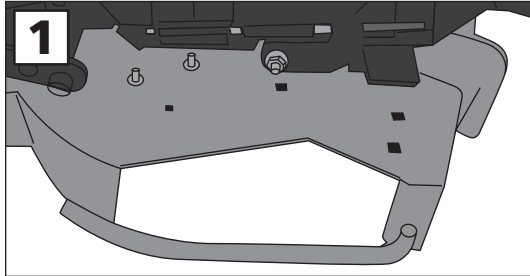

1. Lift the hinged grass deflector on your mower to expose the deck opening (Fig. 1).
2. Hold the pre-cut boot up against the mower deck opening and place the Special Boot Plate on top of the boot as shown in (Fig. 2).

Note: The Boot Plate will not line up with the existing holes in the deck.

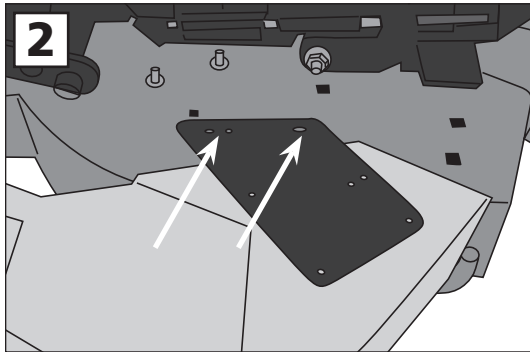

3. Mark the two new holes onto the mower deck with a marker pen. Then, drill both 5/16" holes for the mounting bolts (Fig. 2).
4. Push the two 5/16" x 1.5" bolts up through the bottom of the mower deck and screw them into the threaded holes in the Support Blocks. You will now have two threaded studs protruding up from your mower deck (Fig 3).
5. Drop the Boot Plate over the threaded studs and spin on the Boot Plate Clamp Knobs. Position the boot under the boot plate and flush against the deck opening. While holding the boot in place, mark the four bolt hole positions with a marker pen (Fig 4).

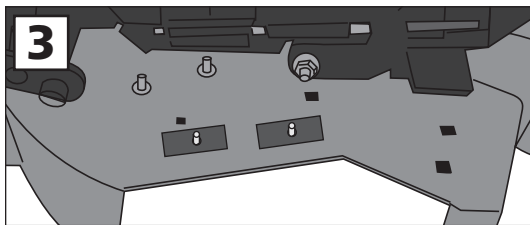

6. Loosen the Clamp Knobs and remove the Boot Plate from your mower deck. Place the boot on a stable surface. Using the Boot Plate as a template, drill four 5/16" holes through the boot in the four bolt positions you marked. The best way is to first drill one hole, and then drop a bolt through the hole temporarily to keep the plate lined up. Repeat the process until all holes have been drilled. Install the mounting bolts and tighten. The bolt heads should be on the inside to avoid blocking the boot opening. (Fig 5).

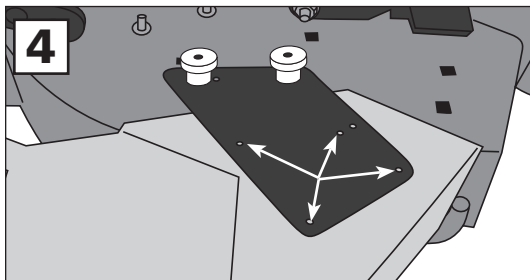

7. Install the MDA onto the mower deck. Place one rubber washer on each stud. Spin on the Boot Plate Clamp Knobs and tighten.
8. Attach the hose collar onto the MDA with the latches provided. Cut the hose to length as described in your Cyclone Rake Owner's Manual

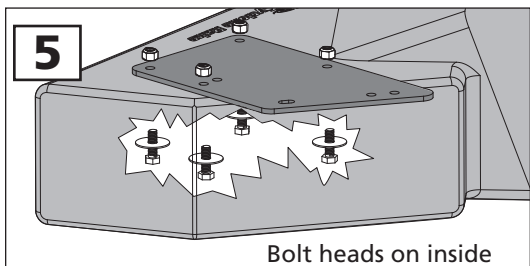

That's it. You're finished.

Parts list on reverse.

COMPONENT LIST

MDA-037

PART NO.	NAME	QTY
01-02-102	Special boot w/strikes	1
05-02-102	Special boot w/strikes - XL	1
06-02-102	Special boot w/strikes - Z-10	1
01-01-150	5/16-18 x 1.5 Full thread bolt	2
01-01-151	5/16-18 Nylon lock nut	4
01-01-152	5/16 Washer type A series W	2
01-01-171	5/16-18 x 1" Hex bolt	4
01-01-175	5/16 Fender washer	4
01-01-291	Clamp knob - Boot Plate	2
01-01-441	Support Block	2
01-01-809	S42 Boot Plate	1
01-01-1990	Rubber washer	2
01-02-125	Support block, 1.5 bolt & washer	2
01-02-564	Standard strike w/hardware	3
01-02-142	8" x 8" Collar complete - green	1
01-02-486	7" x 8" Collar complete	1
05-02-080	8" x 8" Collar complete - yellow	1
06-02-080	10" x 10" Collar complete	1
08-02-080	8" x 6" Collar complete	1

