

Assembly and Installation

This Mower Deck Adapter (MDA) is designed to work with several mower deck designs. The MDA does not need an airtight fit to deliver exceptional vacuum performance. It simply needs to be installed in front of the opening on the mower deck. Follow the instructions below to install.

Safety Note:
If you remove the Mower Deck Adapter later, you MUST re-install the grass deflector.

Mounting the Boot Plate Bracket & Boot Plate to Your Mower Deck

1. Remove the hinged grass deflector from your mower deck to expose the deck opening. On most machines this is just a matter of removing two bolts.
2. Position the TZ-Boot Plate Bracket against the inside of the mower deck flange (Fig 1). If the holes do not line-up, trace the outline of the holes onto the mower deck flange with a marker pen, and drill two 5/16" holes for the mounting bolts.
3. Attach the TZ-Boot Plate Bracket to the mower deck using the two 5/16 x 1-inch bolts and nuts. Thread the two 5/16 x 1.5-inch full thread bolts up through the TZ-Boot Plate Bracket. Drop the TZ-Boot Plate over the bolts and spin on the Boot Plate Clamp Knobs (Fig. 2a).

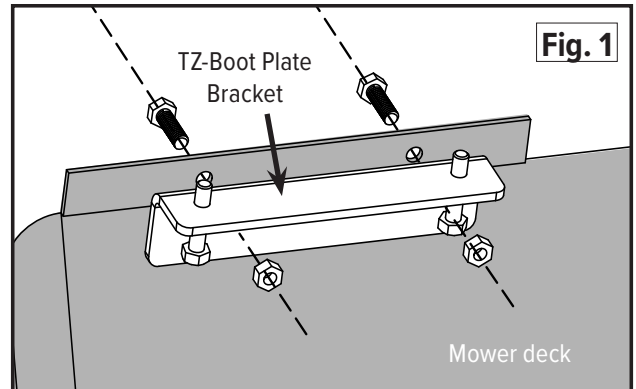

Note: In some cases the TZ-Boot Plate must be flipped over (Fig.2b).

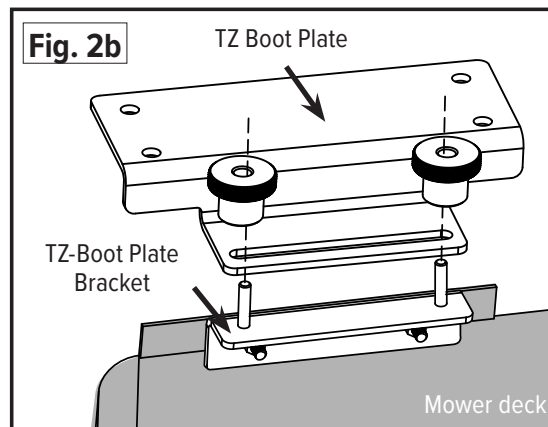
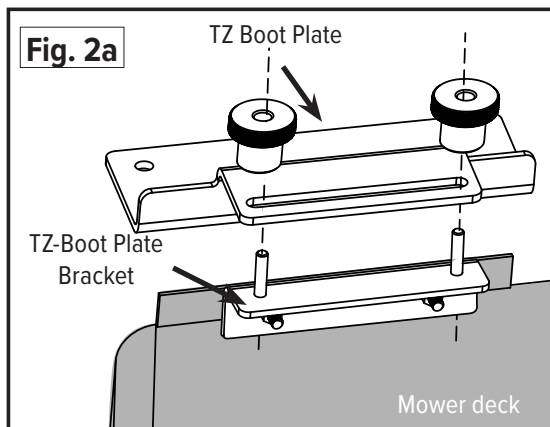

Mounting the Boot

1. Hold the boot snugly against the lower surface of the TZ- Boot Plate directly in front of the deck opening (the boot may be moved forward or backward as necessary). Mark the four bolt hole positions with the marker pen (see Fig. 3 on reverse). Loosen the Clamp Knobs and remove the TZ- Boot Plate from your mower deck.

Continued on Reverse.

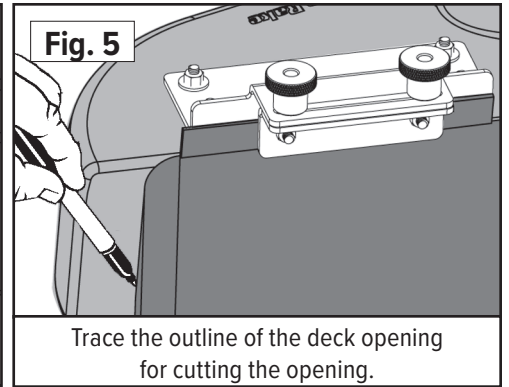
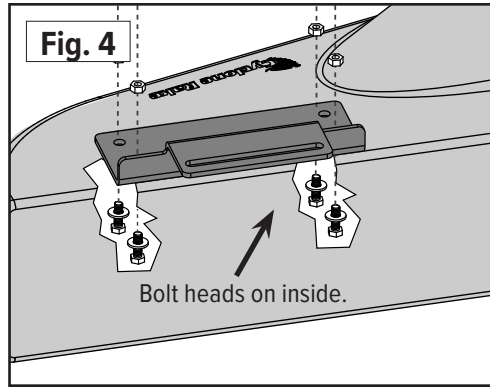
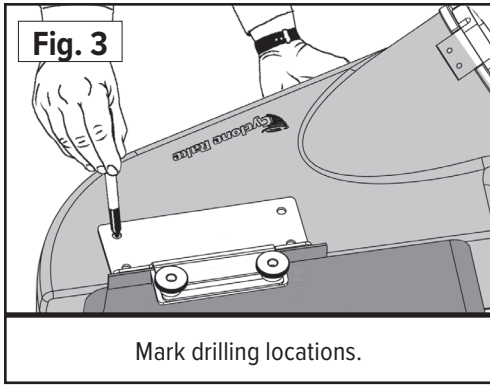

3. Place the boot on a stable surface. Using the TZ- Boot Plate as a template, drill four 5/16" holes through the boot in the four bolt positions. The best way is to first drill one hole, and then drop a bolt through the hole temporarily to keep the plate lined up. Repeat the process until all holes have been drilled. Remove the bolts.
4. Install the mounting bolts and tighten. The bolt heads should be on the inside, to avoid blocking the boot opening (Fig. 4).
5. Install the MDA on the mower deck. Trace around the deck opening with the marker pen (Fig. 5). Then remove the MDA from the mower deck.
6. Drill a starter hole inside the marked area, (Fig. 6) and use an electric jigsaw or keyhole saw to cut the boot to the shape of your deck opening. Place the MDA assembly back onto the deck studs, then place one rubber washer on each stud. Now, spin on the Clamp Knobs and tighten all the bolts.
7. Snap the hose collar onto the MDA with the latches provided. Cut the hose to length as described in your owner's manual.

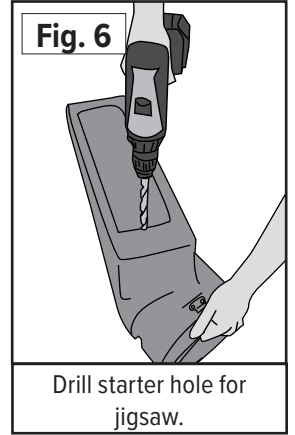

That's it you're finished.

MDA-028 COMPONENT LIST

PART NO.	NAME	QTY
01-02-143	Standard Boot w/strikes	1
05-02-143	Standard Boot w/strikes - XL	1
06-02-143	Standard Boot w/strikes - Z-10	1
01-01-150	5/16-18 x 1.5 full threaded bolt	2
01-01-151	5/16-18 Nylon lock nut	6
01-01-171	5/16-18 x 1 Hex bolt	6
01-01-175	5/16 Fender washer	4
01-01-291	Clamp knob - Boot Plate	2
01-01-1903	TZ-Boot Plate	1
01-01-1904	TZ-Boot Plate Bracket	1
01-01-1990	Rubber washer	2
01-02-564	Standard strike w/hardware	3
01-02-142	8" x 8" Collar complete - green	1
01-02-486	7" x 8" Collar complete	1
05-02-080	8" x 8" Collar complete - yellow	1
06-02-080	10" x 10" Collar complete	1
08-02-080	8" x 6" Collar complete	1

