

Assembly and Installation

This Mower Deck Adapter (MDA) is designed to work with several mower deck designs. The MDA does not need an airtight fit to deliver exceptional vacuum performance. It simply needs to be installed in front of the opening on the mower deck. Follow the instructions below to install.

Mounting the Mower Deck Adapter to Your Mower Deck

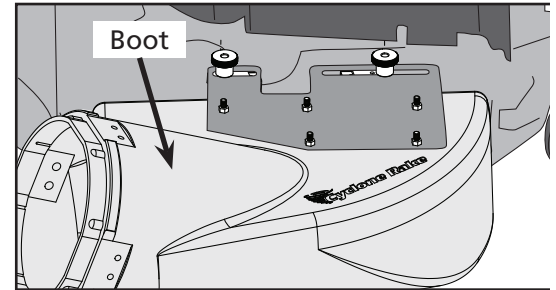

Finished assembly of the 023 Mower Deck Adapter™ with quick release deck connection

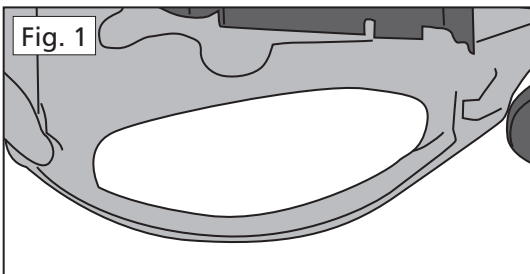

1. Remove the hinged grass deflector from your mower deck to expose the deck opening (Fig. 1). On most machines this is just a matter of removing two bolts.

Safety Note: If you remove the Mower Deck Adapter later, you MUST re-install the grass deflector.

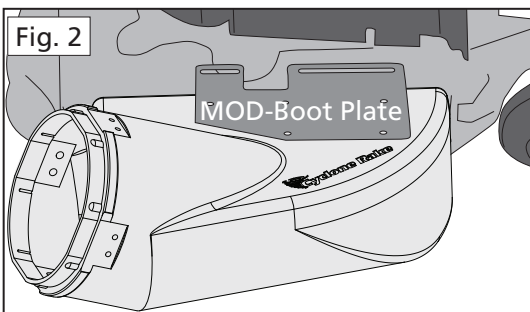

2. Hold the pre-cut boot up against the mower deck opening and place the MOD-Boot Plate on top of the boot. The slotted portion will hang over the top of the mower deck surface. (Fig. 2)

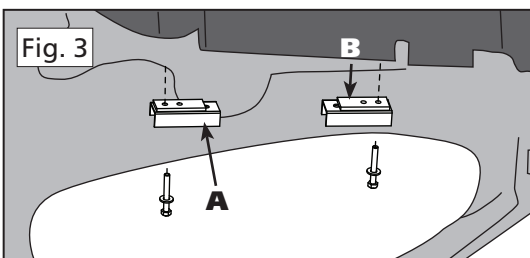

3. Trace the outline of the slots onto your mower deck with a marker pen. Drill two 5/16" holes for the mounting bolts within each slot range. Push the two 5/16" x 2" bolts up through the bottom of the mower deck. Thread the bolts into the Boot Plate Spacers (A) and Support Blocks (B). The bolt heads should be on the inside of the mower deck. The U-shaped Boot Plate Spacers should point down when installed. Tighten securely. (Fig. 3)

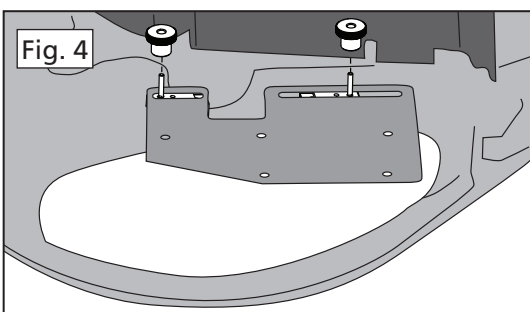

4. Position the Boot Plate over the mower deck mounting bolts and secure with the two Boot Plate Clamp Knobs. (Fig. 4)

Continued on Reverse.

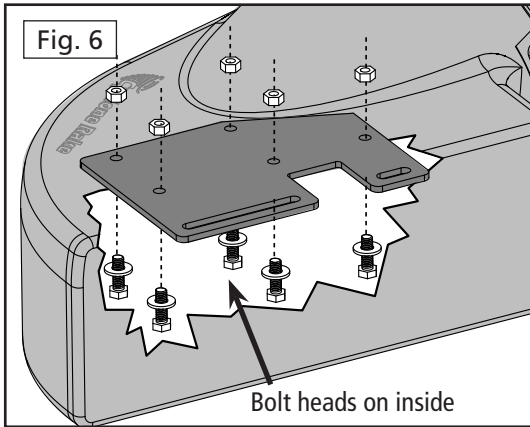
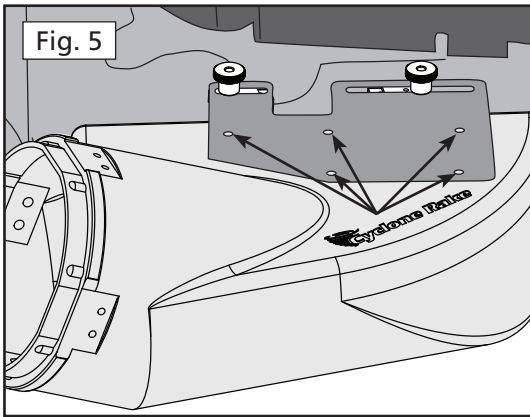

5. Hold the boot snugly against the lower surface of the Boot Plate and also up against the deck opening. While holding the boot in place mark the five bolt hole positions for the Boot Plate with a marker pen. Loosen the Clamp Knobs and remove the Boot Plate from your mower deck (Fig. 5).
6. Place the boot on a stable surface. Using the Boot Plate as a template, drill five 5/16" holes through the boot in the five bolt positions. The best way is to first drill one hole, and then drop a bolt through the hole temporarily to keep the plate lined up. Repeat the process until all holes have been drilled.
7. Install the 5/16 x 1" mounting bolts and tighten. The bolt heads should be on the inside to avoid blocking the boot opening (Fig 6).
8. Install the MDA on the mower deck. Place one rubber washer on each mounting bolt. Spin on the Boot Plate Clamp Knobs over the bolts and you're finished.
9. Snap the hose collar onto the MDA with the latches provided. Cut the hose to length as described in your owner's manual.

That's it you're finished.

**COMPONENT LIST
MDA-023**

PART NO.	NAME	QTY
01-02-145	Short Boot w/strikes	1
05-02-145	Short Boot w/strikes - XL	1
06-01-145	Short Boot w/strikes - Z-10	1
01-01-1344	MOD Boot Plate	1
01-01-151	5/16-18 Nylon lock nut	5
01-01-152	5/16 Washer	2
01-01-153	5/16-18 x 2 Hex bolt	2
01-01-171	5/16-18 x 1 Hex bolt	5
01-01-175	5/16 Fender washer	5
01-01-291	Clamp Knob - Boot Plate	2
01-01-441	Support Block	2
01-01-495	Boot plate spacer	2
01-01-1990	Rubber washer	2
01-02-564	Standard strike w/hardware	3
01-02-142	8" x 8" Collar complete - green	1
01-02-486	7" x 8" Collar complete	1
05-02-080	8" x 8" Collar complete - yellow	1
06-02-080	10" x 10" Collar complete	1
08-02-080	8" x 6" Collar complete	1

