

Assembly and Installation

This Mower Deck Adapter (MDA) is designed to work with several mower deck designs. The MDA does not need an airtight fit to deliver exceptional vacuum performance. It simply needs to be installed in front of the opening on the mower deck. Follow the instructions below to install.

1. Remove the hinged grass deflector shield and hinge bracket from your mower deck to expose the deck opening.

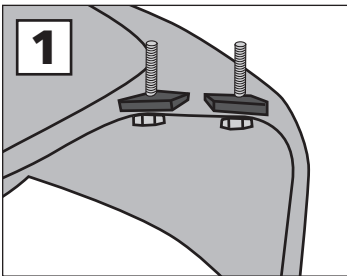

2. Install the two 5/16 x 1.5-inch hex bolts and washers from the bottom of the mower deck into the threaded holes in the rectangular Support Blocks. Tighten firmly. You will now have two threaded studs protruding from your mower deck. (Fig. 1)

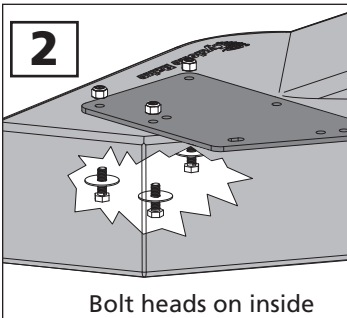

3. Install the three 5/16 x 1-inch bolts, each with a 5/16 fender washer, up through the inside of the boot and the boot plate. Secure with the 5/16 nylon lock nuts. (Fig. 2)

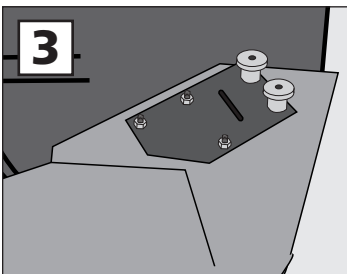

4. Install the MDA assembly onto the mower deck. Place one rubber washer on each stud. Spin on the Boot Plate Clamp Knobs over the mounting bolts.

5. Connect the hose collar onto the MDA with the latches and cut the hose to length as described in your owner's manual if needed.

That's it you're finished!

Safety Note:
If you remove the Mower Deck Adapter later, you MUST re-install the grass deflector.

COMPONENT LIST MDA-016

PART NO.	NAME	QTY
01-02-102	Special Boot w/strikes	1
05-02-102	Special Boot w/strikes- XL	1
06-02-102	Special Boot w/strikes- Z-10	1
01-01-150	5/16-1.5 Full thread bolt	2
01-01-151	5/16" Nylon lock nuts	3
01-01-152	5/16 Washer - type A series W	2
01-01-171	5/16-18 x 1 Hex bolt	3
01-01-175	5/16 Fender washer	3
01-01-291	Clamp Knob	2
01-01-441	Support Block	2
01-01-1440	H-Boot Plate	1
01-01-1990	Rubber washer	2
01-02-125	Support block, 1.5 bolt & washer	2
01-02-564	Standard strike w/hardware	3
01-02-142	8" x 8" Collar complete - green	1
01-02-486	7" x 8" Collar complete	1
05-02-080	8" x 8" Collar complete - yellow	1
06-02-080	10" x 10" Collar complete	1
08-02-080	8" x 6" Collar complete	1

