

This Mower Deck Adapter (MDA) is designed to work with several mower deck designs. The MDA does not need an airtight fit to deliver exceptional vacuum performance. It simply needs to be installed in front of the opening on the mower deck. Follow the instructions below to install.

## Mounting the Boot Plate To Your Mower Deck

1. Remove the grass deflector from your mower deck to expose the deck opening.

**Safety Note:** If you remove the Mower Deck Adapter later, you MUST re-install the grass deflector.

2. Position the two Boot Plate Spacers (A) on top of the mower deck, next to the mower deck flange. The two Boot Plate Spacers should be placed with the U-shape facing down and positioned approximately 8 inches apart.
3. Flip the spacers U-shape up and mark the location of the outer holes in the Boot Plate Spacers with a marker pen (Fig. 1).
4. Using a 5/16" drill bit, drill two 5/16" holes in the top of the mower deck to accommodate the Cyclone Rake mower deck mounting bolts.
5. Insert two 5/16 x 2 inch hex bolts through the holes in the mower deck. Thread the bolts into the Boot Plate Spacers and Support Blocks (B). The bolt heads should be on the inside of the mower deck. The U-shaped Boot Plate Spacers should point down when installed. Tighten securely (Fig. 1).
6. Position the Boot Plate over mower deck mounting bolts and secure with the two Boot Plate Clamp Knobs (Fig. 2).

## Mounting the Boot

1. Hold the boot snugly against the underside of the Boot Plate directly in front of the deck opening (the boot may be moved forward or backward as necessary). Mark the four bolt hole positions in the Boot Plate with the marker pen (Fig. 3). Loosen the clamp knobs and remove the Boot Plate from your mower deck.

*Continued on Reverse.*

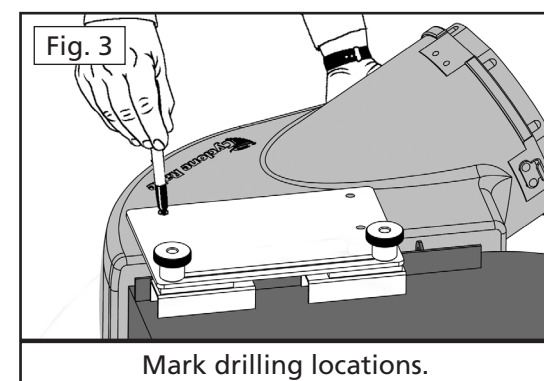
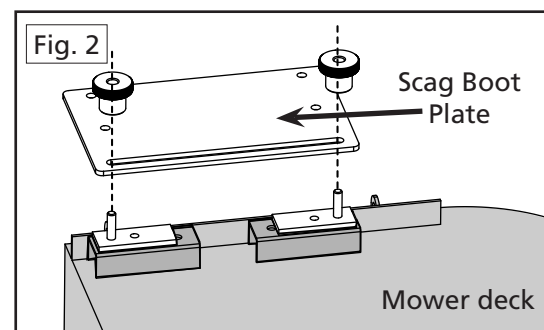
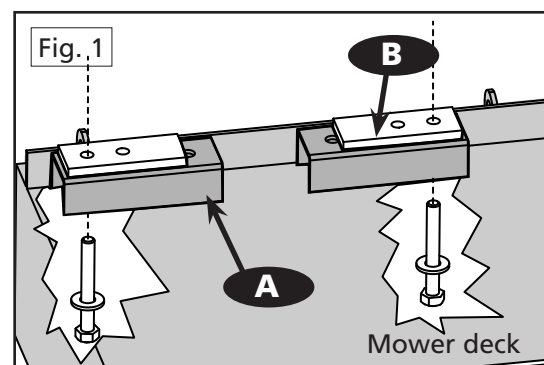
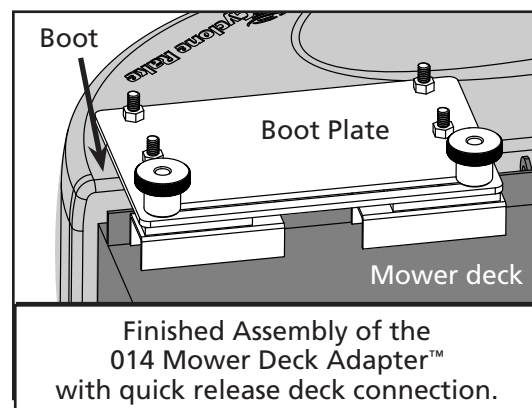

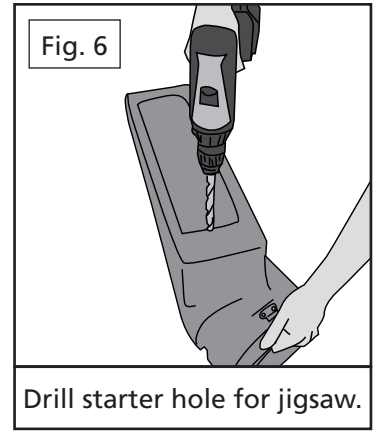
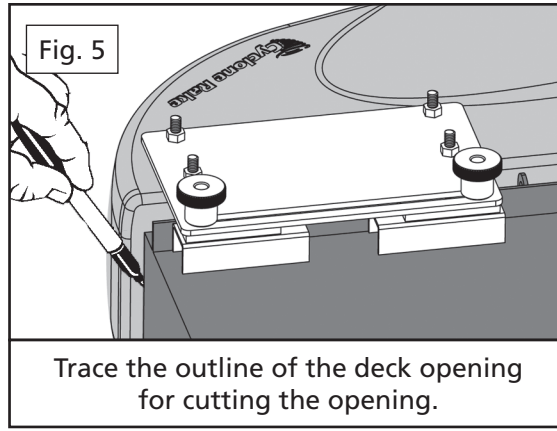
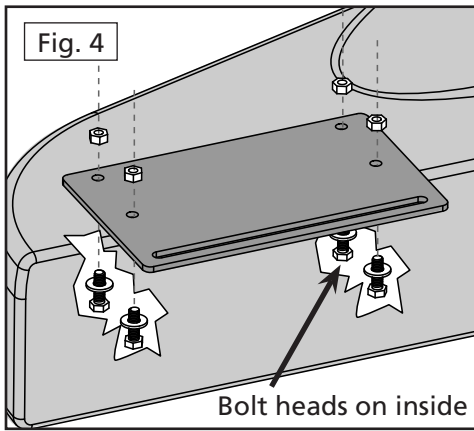

- Place the boot on a stable surface. Using the Boot Plate as a template, drill four 5/16" holes through the boot in the four bolt positions. The best way is to first drill one hole, and then drop a bolt through the hole temporarily to keep the plate lined up. Repeat the process until all holes have been drilled. Remove the bolts.
- Install the four 5/16 x 1-inch Boot Plate mounting bolts, fender washers and nuts. The bolt heads should be on the inside, to avoid blocking the boot opening (Fig. 4).
- Install the MDA on the mower deck. Trace around the deck opening with the marker pen (Fig. 5). Then remove the MDA from the mower deck.
- Drill a starter hole inside the marked area, (Fig. 6) and use an electric jigsaw or keyhole saw to cut the boot to the shape of your deck opening. Place the MDA assembly back onto the deck studs, then place one rubber washer on each stud. Now, spin on the Clamp Knobs and tighten all the bolts.
- Snap the hose collar onto the MDA with the latches provided. Cut the hose to length as described in your owner's manual.

***That's it you're finished.***

**COMPONENT LIST  
MDA-014**

| PART NO.   | NAME                             | QTY |
|------------|----------------------------------|-----|
| 01-02-145  | Short Boot w/strikes             | 1   |
| 05-02-145  | Short Boot w/strikes - XL        | 1   |
| 06-02-145  | Short Boot w/strikes - Z-10      | 1   |
| 01-01-151  | 5/16-18 Nylon lock nut           | 4   |
| 01-01-152  | 5/16 Washer - type A series W    | 2   |
| 01-01-153  | 5/16-18 x 2 Hex bolt             | 2   |
| 01-01-171  | 5/16-18 x 1 Hex bolt             | 4   |
| 01-01-175  | Fender washer                    | 4   |
| 01-01-291  | Clamp Knob - Boot Plate          | 2   |
| 01-01-441  | Support Block                    | 2   |
| 01-01-495  | Boot Plate "U" shaped spacer     | 2   |
| 01-01-775  | S-Boot Plate                     | 1   |
| 01-01-1990 | Rubber washer                    | 2   |
| 01-02-564  | Standard strike w/hardware       | 3   |
| 01-02-142  | 8" x 8" Collar complete - green  | 1   |
| 01-02-486  | 7" x 8" Collar complete          | 1   |
| 05-02-080  | 8" x 8" Collar complete - yellow | 1   |
| 06-02-080  | 10" x 10" Collar complete        | 1   |
| 08-02-080  | 8" x 6" Collar complete          | 1   |

