

Assembly and Installation

This Mower Deck Adapter (MDA) is designed to work with several mower deck designs. The MDA does not need an airtight fit to deliver exceptional vacuum performance. It simply needs to be installed in front of the opening on the mower deck. Follow the instructions below to install.

1. Fig 1: Remove the grass deflector from your mower deck to expose the deck opening.

Safety Note: If you remove the Mower Deck Adapter later, you MUST re-install the grass deflector.

2. Fig 2: Position the Cover plate (01-01-2203) on top of the deck opening where the recessed area is to cover the gap. Mark the location of the holes in the cover plate onto the mower deck. Remove the Cover Plate and drill the holes into the mower deck using a 5/16 drill bit.
3. Fig 3: Push the two 5/16 x 1.5-inch full-thread bolts up through the bottom of the mower deck, through the Cover Plate, and screw them into the threaded holes in the small rectangular Support Blocks. Line the two blocks up parallel with each other and tighten firmly with a wrench. You will now have two threaded studs protruding up from your mower deck.
4. Fig 4: Next, install the Boot Plate over the threaded studs with four holes overhanging over your mower deck and secure with the 2 Boot Plate Clamp Knobs. Hold the boot snugly against the lower surface of the plate directly in front of the deck opening (the boot may be moved forward or backward as necessary for installation). Mark the four bolt hole positions with the marker pen. Loosen the clamp knobs and remove the boot plate from your mower deck.
5. Place the boot on a stable surface. Using the Boot Plate as a template, drill four 5/16" holes through the boot in the four bolt positions. The best way is to first drill one hole, then drop a bolt through the hole temporarily to keep the plate lined up. Repeat the process until all four holes have been drilled. Remove the bolts.
6. Fig 5: Place the two metal Boot Plate Spacers between the boot and the Boot Plate with the "U" arms facing up. Install the four 5/16 x 2-inch mounting bolts and tighten. The bolt heads should be on the inside to avoid blocking the boot opening.

Continued on Reverse.

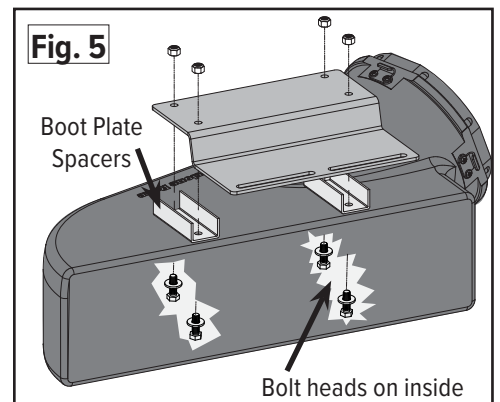
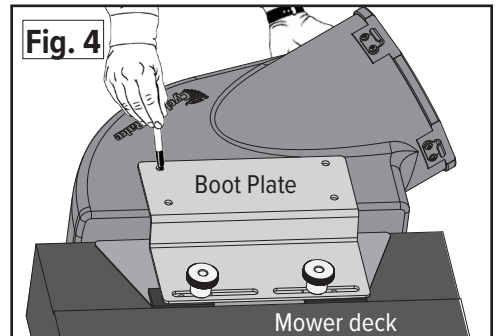
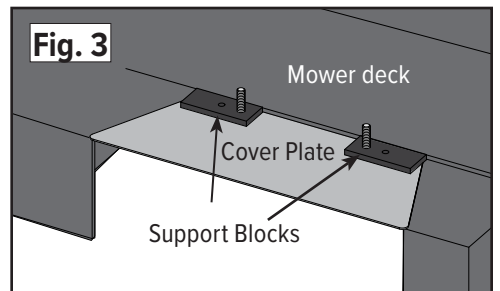
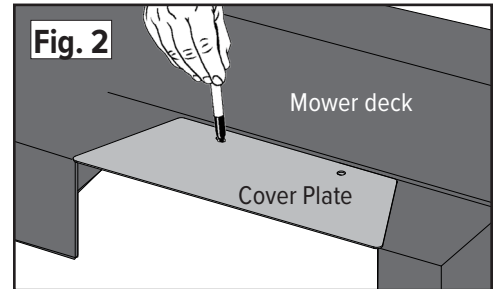

7. Fig 6: Install the MDA on the mower deck. Trace around the deck opening with the marker pen. Then remove the MDA from the mower deck.
8. Fig. 7: After tracing deck opening, drill 4 starter holes inside the corners of the marked area, then use an electric jigsaw or keyhole saw to cut the boot to the shape of your deck opening. This will avoid sharp corners that can lead to cracking. Next, place the MDA assembly back onto the deck studs, and place one rubber washer on each stud. Now, spin on the Clamp Knobs and tighten all the bolts.
9. Attach the hose collar onto the MDA with the latches and cut the hose to length as described in your owner's manual.

That's it you're finished.

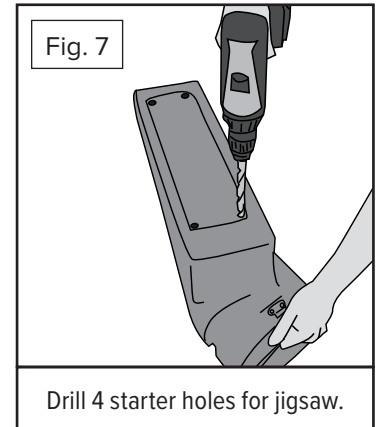
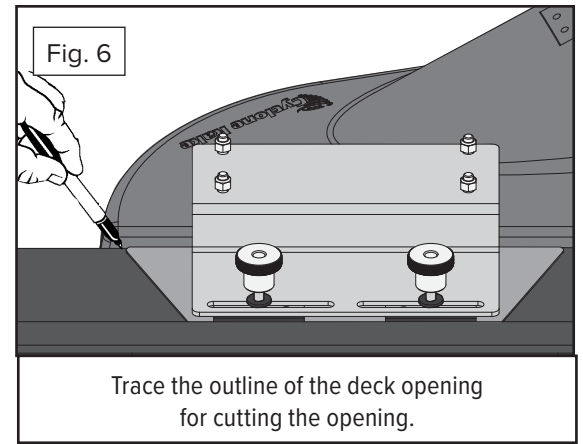

MDA 059 COMPONENT LIST

PART NO.	NAME	QTY
01-02-145	Short Boot w/strikes	1
05-02-145	Short Boot w/strikes - XL	1
06-02-145	Short Boot w/strikes - Z-10	1
01-01-151	5/16-18 Nylon lock nut	4
01-01-152	5/16 Washer - type A series W	2
01-01-153	5/16-18 x 2 Hex bolt	2
01-01-175	Fender washer	4
01-01-291	Clamp Knob - Boot Plate	2
01-01-441	Support Block	2
01-01-495	Boot Plate "U" shaped spacer	2
01-01-1990	Rubber washer	2
01-01-1335	5/16-18 x 1.5 Hex bolt	2
01-01-2022	G-Boot Plate	1
01-01-2203	G-Cover Plate	1
01-02-564	Standard strike w/hardware	3
01-02-142	8" x 8" Collar complete - green	1
01-02-486	7" x 8" Collar complete	1
05-02-080	8" x 8" Collar complete - yellow	1
06-02-080	10" x 10" Collar complete	1
08-02-080	8" x 6" Collar complete	1

