

## Assembly and Installation

This Mower Deck Adapter (MDA) is designed to work with several mower deck designs. The MDA does not need an airtight fit to deliver exceptional vacuum performance. It simply needs to be installed in front of the opening on the mower deck. Follow the instructions below to install.

1. Fig. 1: Remove the hinged grass deflector from your mower deck to expose the deck opening.

**Safety Note: If you remove the Mower Deck Adapter later, you MUST re-install the grass deflector.**

2. Fig. 2: Position the Cover plate (01-01-2200) on top of the deck opening where the recessed area is to cover the gap. Then mark the location of the holes in the cover plate onto the mower deck. Drill the holes into the mower deck using a 3/8 drill bit.

3. Fig.3: Install one of the 5/16-18 x 1-inch bolt into the top of each Boot Bracket.

4. Fig. 4: Then install the 3/8 x 1-inch bolt with a washer up from the bottom of the mower deck, through one of the holes in the cover plate. Place one of the boot brackets on top of the bolt and secure with a 3/8 nylon lock nut.

5. Repeat with the other Boot Bracket.

6. Fig. 5: Place the Boot Plate over the bolts protruding from the top of the Boot Brackets. Place one rubber washer on each bracket stud. Spin on the Boot Plate Clamp Knobs and tighten. Then, hold the boot snugly against the lower surface of the plate directly in front of the deck opening (the boot may be moved forward or backward as necessary for installation). Mark the four bolt hole positions with the marker pen. Loosen the clamp knobs and remove the boot plate from your mower deck.

7. Place the boot on a stable surface. Using the Boot Plate as a template, drill four 5/16" holes through the boot in the four bolt positions you just marked. The best way is to first drill one hole, then drop a bolt through the hole temporarily to keep the plate lined up. Repeat the process until all four holes have been drilled.

8. Fig. 6: Install the four mounting bolts, washers & Lock nuts up from the inside of the boot and tighten. The bolt heads should be on the inside, to avoid blocking the boot opening.

**Continued on Reverse.**

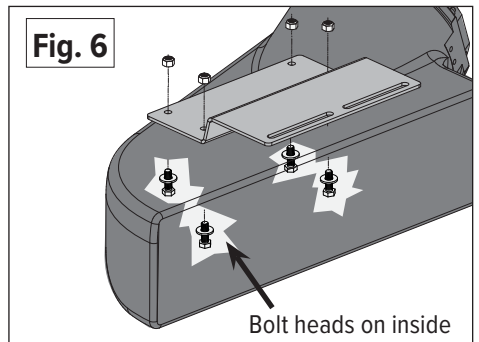
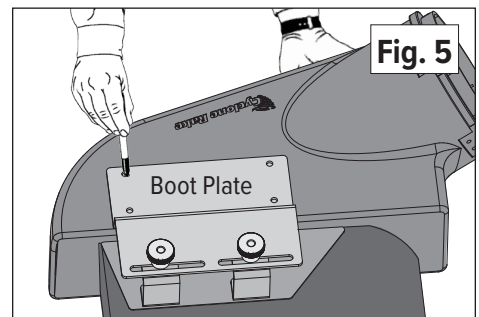
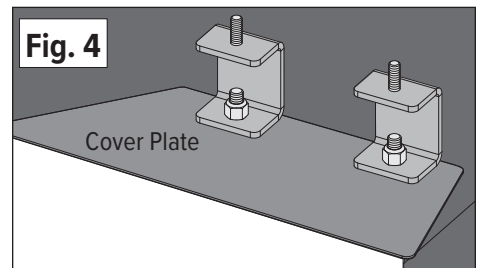
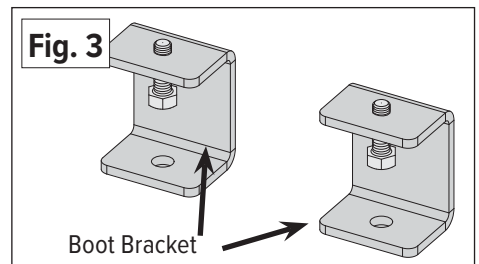
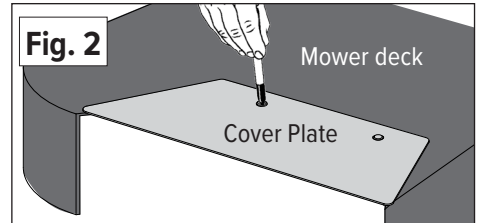

9. Fig. 7: Install the MDA on the mower deck. Trace around the deck opening with the marker pen. Then remove the MDA from the mower deck.

10. Fig. 8: After tracing deck opening, drill 4 starter holes inside the corners of the marked area, then use an electric jigsaw or keyhole saw to cut the boot to the shape of your deck opening. This will avoid sharp corners that can lead to cracking. Next, place the MDA assembly back onto the deck studs, and place one rubber washer on each stud. Now, spin on the Clamp Knobs and tighten all the bolts.

11. Attach the hose collar onto the MDA with the latches and cut the hose to length as described in your owner's manual.

***That's it, your finished!***

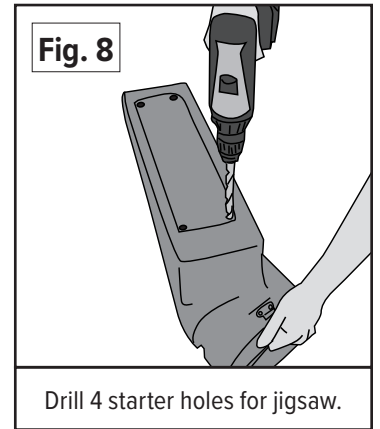
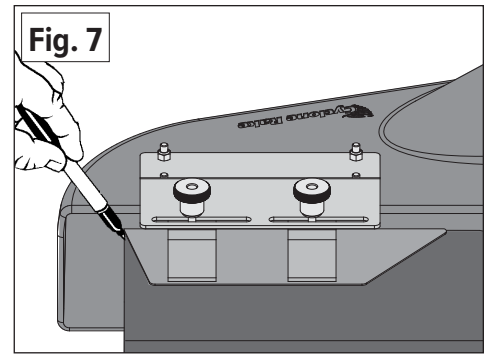

**MDA-057 COMPONENT LIST**

PART NO.	NAME	QTY
01-02-143	Standard Boot w/strikes	1
05-02-143	Standard Boot w/strikes - XL	1
06-02-143	Standard Boot w/strikes - Z-10	1
01-01-151	5/16-18 Nylon lock nut	4
01-01-171	5/16-18 x 1 Hex bolt	6
01-01-175	5/16 Fender washer	4
01-01-180	3/8 Flat washer	2
01-01-240	3/8-16 Nylon Lock nut	2
01-01-291	Clamp Knob - Boot Plate	2
01-01-408	3/8-16 x 1 Hex bolt	2
01-01-1397	CC Boot Bracket	2
01-01-1990	Rubber washer	2
01-01-2022	G Boot Plate	1
01-01-2200	T Cover Plate	4
01-02-564	Standard strike w/hardware	3
01-02-142	8" x 8" Collar complete - green	1
01-02-486	7" x 8" Collar complete	1
05-02-080	8" x 8" Collar complete - yellow	1
06-02-080	10" x 10" Collar complete	1
08-02-080	8" x 6" Collar complete	1

