

## Assembly and Installation

This Mower Deck Adapter (MDA) is designed to work with several mower deck designs. The MDA does not need an airtight fit to deliver exceptional vacuum performance. It simply needs to be installed in front of the opening on the mower deck. Follow the instructions below to install.

**Safety Note:**  
**If you remove the Mower Deck Adapter later, you *MUST* re-install the grass deflector.**

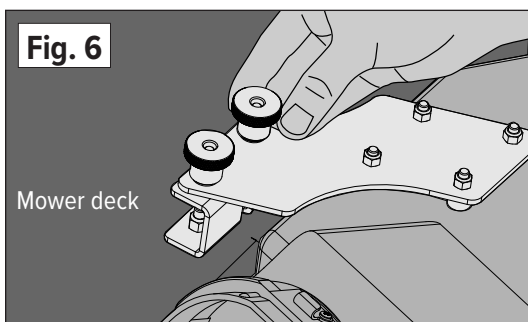
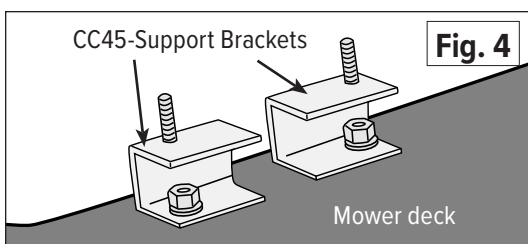
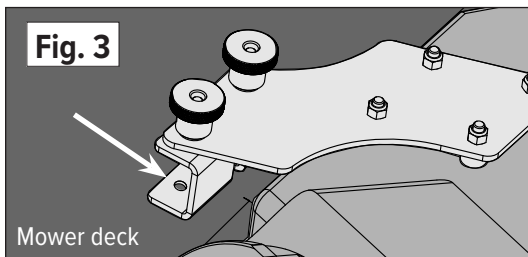
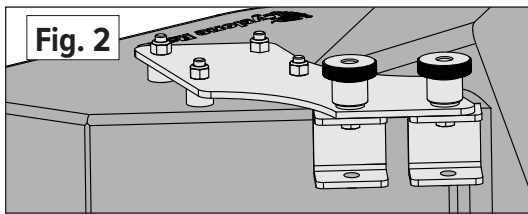
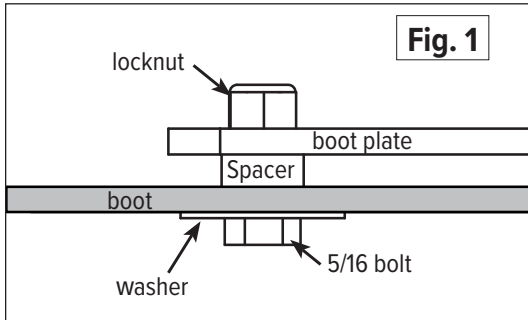

1. Remove grass deflector from mower by removing the pivot rod and spring assembly. (Caution the spring is under extreme tension.) Save the parts so that you can re-install it later.
2. Install the four 5/16-18 x 1.5-inch bolts, each with a 5/16ths fender washer, up through the inside of the boot, add one spacer and place the boot plate on top. Secure with the 5/16" nylon lock nuts. (Fig. 1)
3. Screw one 5/16-18 x 1.25-inch bolt up through the top of each CC45 bracket and then up into the bottom of the boot plate. Secure with the Clamp Knobs. (Fig. 2)
4. Place the entire boot plate assembly onto the mower deck, checking for proper coverage of the deck opening. Mark the location of the holes in the bottom of the CC45 support brackets onto the deck with a marker pen. (Fig. 3)
5. Remove the MDA assembly and then drill two 3/8" holes for the mounting bolts.
6. Remove both of the CC45 Support Brackets from the boot plate assembly and then place the brackets on top of the deck, over the holes you just drilled. Push the two 3/8 -16 x 1-inch bolts with washers up through the bottom of the mower deck and through the lower portion of each CC45 Support Bracket and fasten with the 3/8 lock nuts. (Fig. 4)
7. Place the entire MDA assembly onto the brackets. Place one rubber washer on each bracket stud. Spin on the Boot Plate Clamp Knobs and tighten. (Fig. 6)
8. Attach the hose collar onto the MDA with the latches provided. Cut the hose to length as described in your owner's manual.

***That's it. You're finished.***

**Note: Parts List on reverse.**

## MDA-047 COMPONENT LIST

PART NO.	NAME	QTY
01-02-102	Special Boot w/strikes	1
05-02-102	Special Boot w/strikes - XL	1
06-02-102	Special Boot w/strikes - Z-10	1
01-01-150	5/16-18 x 1.5 Full thread bolt	4
01-01-151	5/16-18 Nylon lock nut	4
01-01-175	5/16 Fender washer	4
01-01-180	3/8 Washer	2
01-01-240	3/8-16 Nylon lock nut	2
01-01-291	Clamp knob - Boot Plate	2
01-01-408	3/8-16 x 1 Hex bolt	2
01-01-1660	CC45 Support Bracket	2
01-01-1990	Rubber washer	2
01-01-1863	Spacer-large	4
01-01-2184	HR Boot Plate	1
01-01-2189	5/16-18 x 1.25 Full thread bolt	2
01-02-564	Standard strike w/hardware	3
01-02-142	8" x 8" Collar complete - green	1
01-02-486	7" x 8" Collar complete	1
05-02-080	8" x 8" Collar complete - yellow	1
06-02-080	10" x 10" Collar complete	1
08-02-080	8" x 6" Collar complete	1

