

Assembly and Installation

This Mower Deck Adapter (MDA) is designed to work with several mower deck designs. The MDA does not need an airtight fit to deliver exceptional vacuum performance. It simply needs to be installed in front of the opening on the mower deck. Follow the instructions below to install.

Mounting the Boot Plate to Your Mower Deck

1. Remove the hinged grass deflector from your mower deck to expose the deck opening. Detach linkages (if any) and remove the Mulch-on-Demand door from the Mower Deck. Remove or tightly secure all loose linkages still remaining under the Mower Deck

Safety Note: If you remove the Mower Deck Adapter later, you MUST re-install the grass deflector.

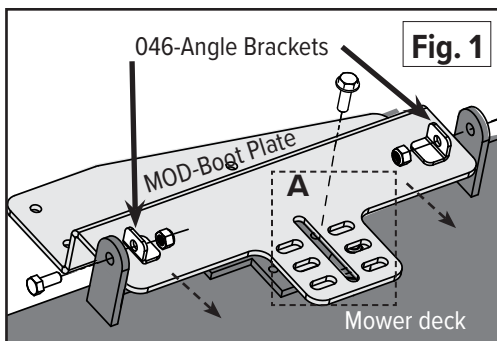

2. Position the boot plate between the Mulch on Demand hinge brackets on the mower deck. Then position the angle brackets on the inside of the hinge brackets. Secure them with the 5/16-18 x 0.75-inch bolts and nylon lock nuts (Fig. 1).
3. Slide the boot plate to align its vertical edge with the edge of the mower deck opening. Mark & drill a 5/16" hole through one of the slots in the boot plate. Choose a slot that will allow you to make contact with the mower deck. (Fig. 1A)
4. Next, install the 5/16" bolt into hole, through the boot plate and mower deck and loosely secure it with a 5/16" lock nut. Do not tighten yet.

Mounting the Boot

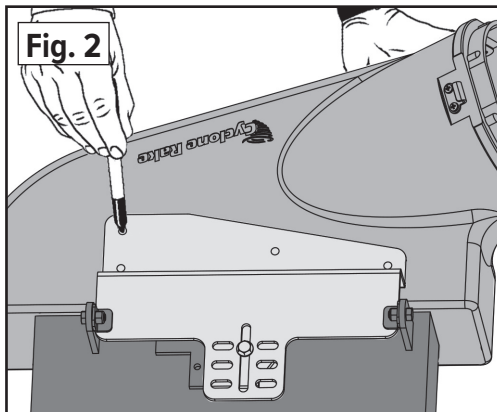

1. Hold the top of the MDA boot snugly against the lower surface of the Boot Plate and directly in front of the deck opening (the boot may be moved forward or backward or side to side as necessary for installation). Mark the four bolt hole positions with the marker pen (Fig. 2).
2. Remove the boot plate from the mower deck. Place the boot on a stable surface. Using the boot plate as a template, drill four 5/16" holes through the boot in the four bolt positions you marked. The best way is to first drill one hole, and then drop a bolt through the hole temporarily to keep the plate lined up. Repeat the process until all holes have been drilled. Remove the bolts.
3. Install the 5/16 x 1-inch mounting bolts each with a fender washer and tighten. The bolt heads should be on the inside, to avoid blocking the boot opening (Fig. 3).

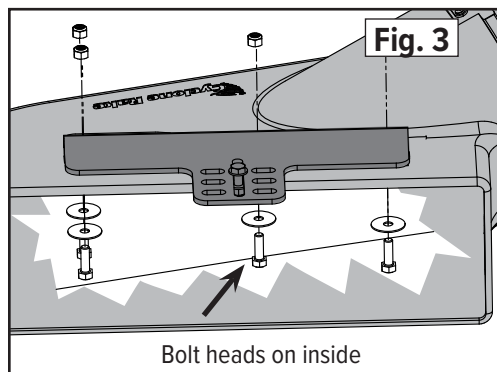

4. Install the MDA on the mower deck by sliding the boot plate under the angle brackets making sure the boot is flush with the deck opening, and loosely reinstall the 5/16" bolt and locknut with a washer on top and bottom. Trace around the deck opening with the marker pen (Fig. 4). Then remove the MDA from the mower deck.
5. Drill a starter hole inside the marked area, (Fig. 5) and use an electric jigsaw or keyhole saw to cut the boot to the shape of your deck opening.
6. Reinstall the MDA assembly back onto the mower deck and tightly secure with the 5/16" bolt and lock nut.
7. Install the hose collar onto the MDA with the latches provided. Cut the hose to length as described in your owner's manual.

That's it you're finished.

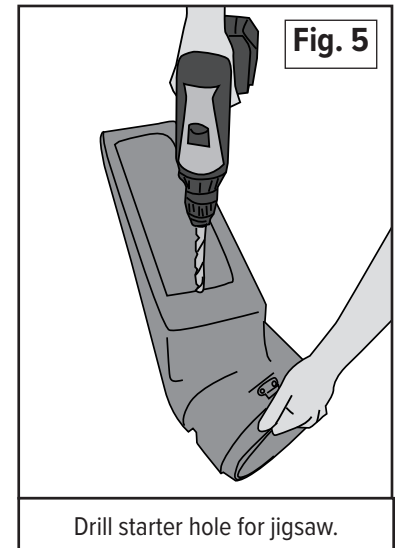
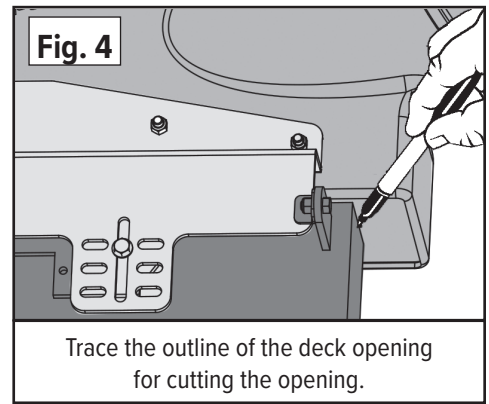

MDA-046 COMPONENT LIST

PART NO.	NAME	QTY
01-02-143	Standard Boot w/strikes	1
05-02-143	Standard Boot w/strikes - XL	1
06-02-143	Standard Boot w/strikes - Z-10	1
01-01-151	5/16-18 Nylon lock nut	7
01-01-152	5/16 Washer - type A series W	4
01-01-171	5/16-18 x 1 Hex bolt	5
01-01-175	Fender washer	4
01-010-1604	5/16-18 x.75 SS Hex bolt	2
01-01-2183	MOD Boot Plate	1
01-01-2185	Angel Bracket-046	2
01-02-564	Standard strike w/hardware	3
01-02-142	8" x 8" Collar complete - green	1
01-02-486	7" x 8" Collar complete	1
05-02-080	8" x 8" Collar complete - yellow	1
06-02-080	10" x 10" Collar complete	1
08-02-080	8" x 6" Collar complete	1

