

Assembly and Installation

This Mower Deck Adapter (MDA) is designed to work with several mower deck designs. The MDA does not need an airtight fit to deliver exceptional vacuum performance. It simply needs to be installed in front of the opening on the mower deck. Follow the instructions below to install.

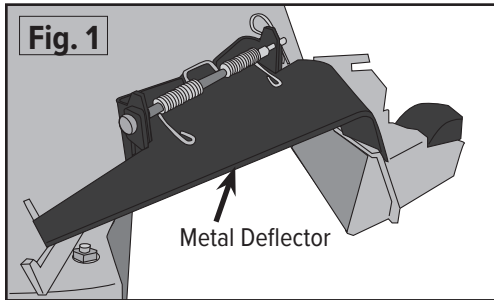

Mounting the Boot Plate to Your Mower Deck

1. On your mower there is a top deflector made of rubber and metal and below that there is a lower deflector made of metal. Remove both from your mower deck. (Caution the spring is under extreme tension.) Then reinstall just the metal deflector. (Fig. 1)

Safety Note: If you remove the Mower Deck Adapter later, you **MUST** re-install the grass deflector.

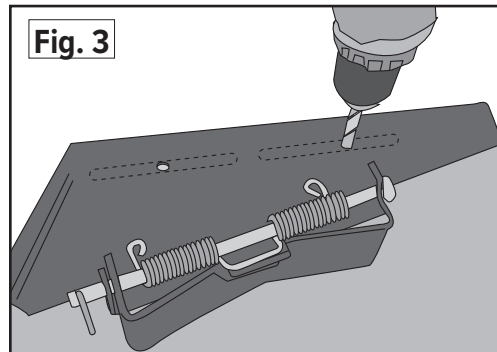
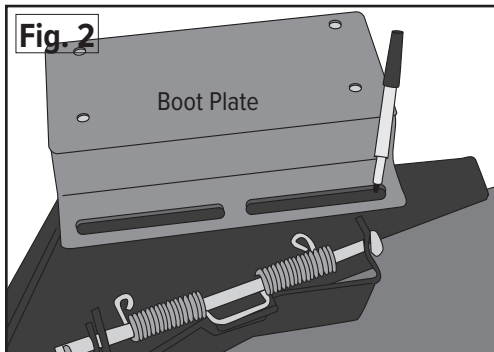

2. Position the boot plate over the bottom deflector so that the large flat area of the plate overhangs your mower deck and the lower part of the plate is flush with the edge of the deflector. Trace the outline of the slots onto your lower deflector with a marker pen. (Fig. 2.)

3. Then drill two 5/16" holes for the mounting bolts. (Fig. 3)

4. Push the two 5/16 x 1.5 inch full-thread bolts up through the bottom of the mower deck and screw them into the threaded holes in the small rectangular Support Blocks (Fig. 4). Line the two blocks up parallel with each other and tighten firmly with a wrench. You will now have two threaded studs protruding up from your lower deflector.

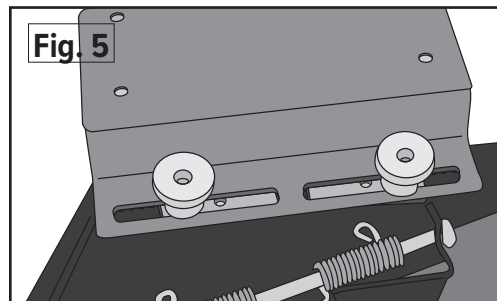
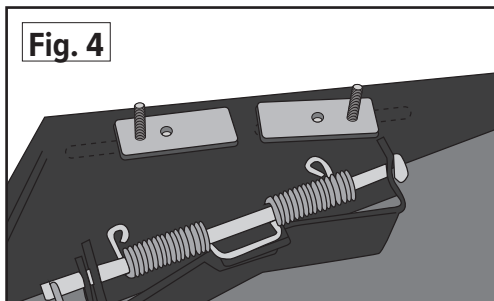

5. Drop the Boot Plate over the threaded studs and spin on the Boot Plate Clamp Knobs. (Fig. 5)

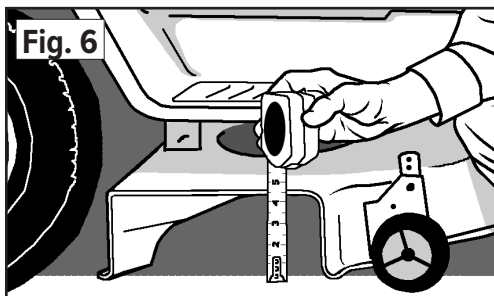

Mounting the Boot

1. First, using a tape measure or ruler, measure the height of your deck opening (Fig. 6). If it is up to 4.5 inches, mount the boot plate directly to the boot. If it is over 4.5 inches in height, use the "U" shaped Boot Plate Spacers (see Fig. 9 on reverse).

IMPORTANT: The arms of the spacers must face up, against the Boot Plate, to avoid cutting into the boot.

Continued on Reverse

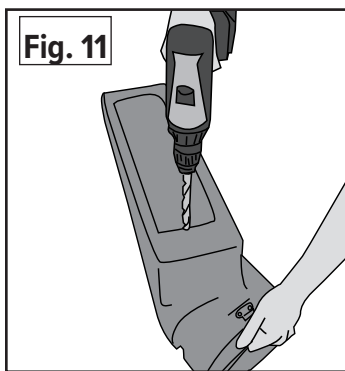
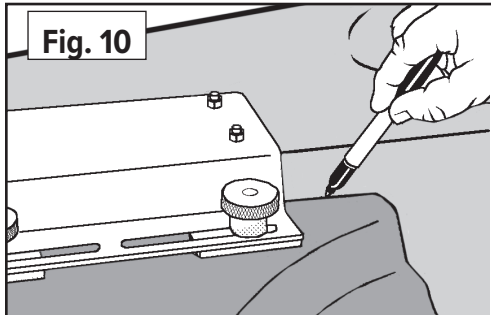
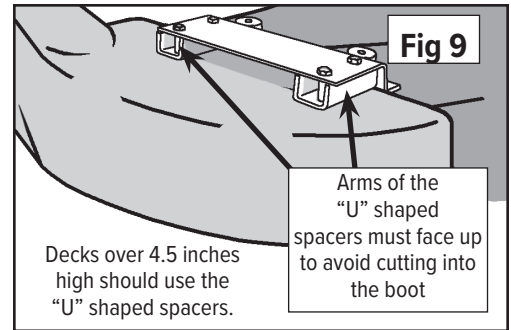
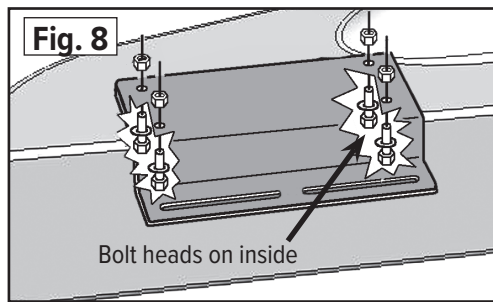
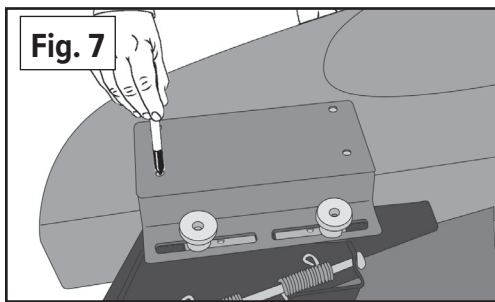

2. Hold the boot snugly against the lower surface of the plate directly in front of the deck opening (the boot may be moved forward or backward as necessary for installation). Mark the four bolt hole positions with the marker pen (Fig. 7). Loosen the clamp knobs and remove the boot plate from your mower deck.
 3. Place the boot on a stable surface. Using the Boot Plate as a template, drill four 5/16" holes through the boot in the four bolt positions. The best way is to first drill one hole, then drop a bolt through the hole temporarily to keep the plate lined up. Repeat the process until all four holes have been drilled. Remove the bolts.
 4. Install the mounting bolts and tighten. The bolt heads should be on the inside, to avoid blocking the boot opening (see Fig. 8).
- NOTE:** For decks over 4.5 inches high, place the two metal Boot Plate Spacers between the boot and the Boot Plate with the "U" arms facing up (Fig. 9). Install the four 5/16 x 2 inch mounting bolts and tighten. The bolt heads should be on the inside to avoid blocking the boot opening (Fig. 8).
5. Install the MDA on the mower deck. Trace around the deck opening with the marker pen (Fig. 10). Then remove the MDA from the mower deck.
 6. Drill a starter hole inside the marked area, (Fig. 11) and use an electric jigsaw or keyhole saw to cut the boot to the shape of your deck opening. Then place the MDA assembly back onto the deck studs, then place one rubber washer on each stud. Now, spin on the Clamp Knobs and tighten all the bolts.
 7. Attach the hose collar onto the MDA with the latches and cut the hose to length as described in your owner's manual.

MDA-045 COMPONENT LIST

PART NO.	NAME	QTY
01-02-143	Standard Boot w/strikes	1
05-02-143	Standard Boot w/strikes - XL	1
06-02-143	Standard Boot w/Strikes - Z-10	1
01-01-069	Standard Boot Plate	1
01-01-150	5/16-18 x 1.5 Full thread bolt	2
01-01-151	5/16 - 18 Nylon lock nut	4
01-01-152	5/16 Washer - type A series W	6
01-01-153	5/16-18 x 2 Hex bolt	4
01-01-171	5/16-18 x 1 Hex bolt	4
01-01-291	Clamp Knob - Boot Plate	2
01-01-441	Support Block	2
01-01-495	Boot Plate Spacer	2
01-01-1990	Rubber washer	2
01-02-125	Support block, 1.5 bolt & washer	2
01-02-564	Standard strike w/hardware	3
01-02-142	8" x 8" Collar complete - green	1
01-02-486	7" x 8" Collar complete	1
05-02-080	8" x 8" Collar complete - yellow	1
06-02-080	10" x 10" Collar complete	1
08-02-080	8" x 6" Collar complete	1

That's it you're finished!

