

Assembly and Installation

This Mower Deck Adapter (MDA) is designed to work with several mower deck designs. The MDA does not need an airtight fit to deliver exceptional vacuum performance. It simply needs to be installed in front of the opening on the mower deck. Follow the instructions below to install.

Mounting the BootPlate to Your Mower Deck

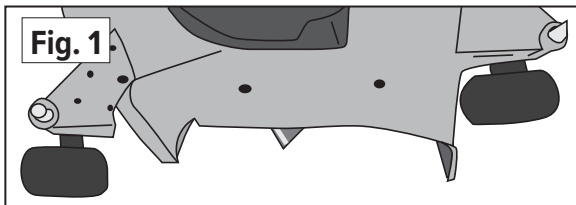
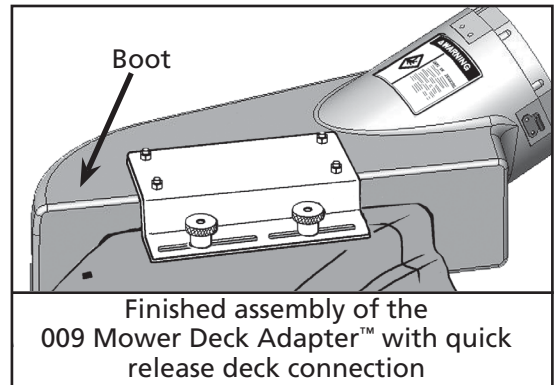

1. Remove the hinged grass deflector from your mower deck to expose the deck opening (Fig. 1). On most machines this is just a matter of removing two bolts.

Safety Note: If you remove the Mower Deck Adapter later, you **MUST** re-install the grass deflector.

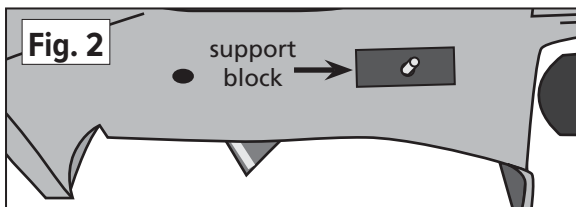

2. Push one of the 5/16 x 1.5 inch bolts up from the bottom of the mower deck, through the hole closest to the front of the deck. Screw it into the threaded support block (Fig. 2).

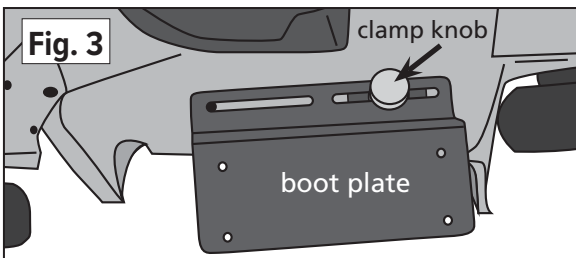

3. Using the first bolt as a reference, place the boot plate™ on the deck and loosely tighten with one boot plate clamp knob (Fig. 3).

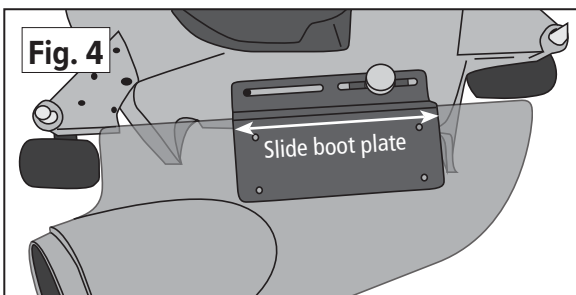

4. Fit the MDA boot onto the mower deck. The front part of the boot will slide over the front portion of the mower deck (Fig. 4). While holding the boot in place, slide the boot plate to adjust the fit and mark the location of the second hole.

NOTE: Some mower decks will require additional cutting of the boot at the rear of the deck opening to allow the boot to slide on properly. Also, in some cases the rear deck wheel will need to be turned out of the way to accommodate the mower deck adapter.

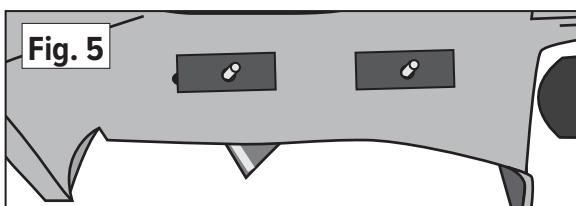

5. Remove the boot plate. Drill the 2nd hole in the top of the mower deck using a 5/16" drill bit. Install the second 5/16 x 1.5 inch bolt up through the hole in the deck. Screw it into the threaded hole of the second support block (Fig. 5).

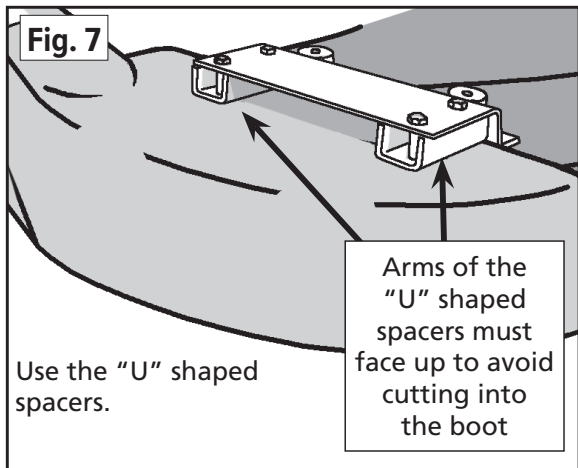
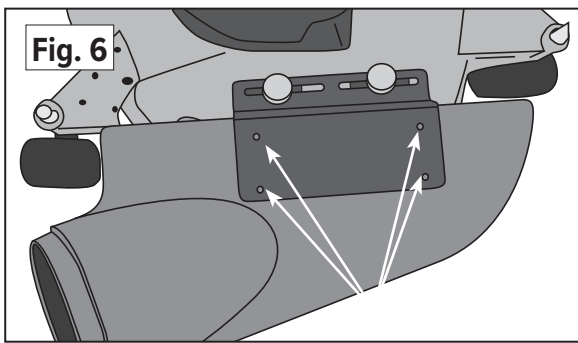

6. Place the boot plate on the mower deck and tighten both clamp knobs. Place the boot on the deck and mark the 4 holes on top of the boot (Fig. 6) with a marker. Loosen the clamp knobs and remove the boot plate from your mower deck.
7. Place the boot on a stable surface. Using the Boot Plate as a template, drill four 5/16" holes through the boot in the four bolt positions. The best way is to first drill one hole, and then drop a bolt through the hole temporarily to keep the plate lined up. Repeat the process until all holes have been drilled, then remove the bolts.
8. Place the two metal boot plate spacers between the boot and the boot plate with the "U" arms facing up (Fig. 7). Install the four 5/16 x 2-inch mounting bolts and tighten.
9. Install the MDA onto the mower deck. Place one rubber washer on each stud. Spin on the Boot Plate Clamp Knobs and tighten.
10. Attach the hose collar onto the MDA with the latches provided. Cut the hose to length as described in your owner's manual.

That's it you're finished.

MDA-009 COMPONENT LIST

PART NO.	NAME	QTY
01-02-143	Standard Boot w/strikes	1
05-02-143	Standard Boot w/strikes - XL	1
06-02-143	Standard Boot w/strikes -Z-10	1
01-01-069	Boot Plate	1
01-01-150	5/16-18 x 1.5 Full-thread bolt	2
01-01-151	5/16-18 Nylon lock nut	4
01-01-152	5/16 Washer - type A series W	6
01-01-153	5/16-18 x 2 Hex bolt	4
01-01-291	Clamp Knob - Boot Plate	2
01-01-441	Support Block	2
01-01-495	Boot Plate Spacer	2
01-01-1990	Rubber washer	2
01-02-125	Support block, 1.5 bolt & washer	2
01-02-564	Standard strike w/hardware	3
01-02-142	8" x 8" Collar complete - green	1
01-02-486	7" x 8" Collar complete	1
05-02-080	8" x 8" Collar complete - yellow	1
06-02-080	10" x 10" Collar complete	1
08-02-080	8" x 6" Collar complete	1

