

## Assembly and Installation

This Mower Deck Adapter (MDA) is designed to work with several mower deck designs. The MDA does not need an airtight fit to deliver exceptional vacuum performance. It simply needs to be installed in front of the opening on the mower deck. Follow the instructions below to install.

### Mounting the Boot Plate to Your Mower Deck

1. Remove the hinged grass deflector from your mower deck to expose the deck opening. On most machines this is just a matter of removing two bolts.

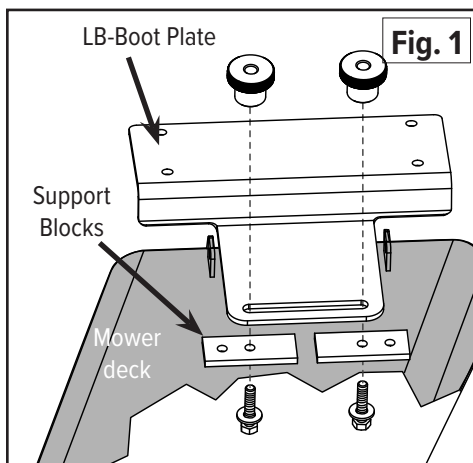

**Safety Note: If you remove the Mower Deck Adapter later, you MUST re-install the grass deflector.**

2. Position the LB-Boot Plate over the deck opening so that the large flat area of the plate overhangs your mower deck. In many cases, the slot in the plate can be positioned over existing holes. If not, trace the outline of the slot onto your mower deck with a marker pen, then drill two 5/16" holes for the mounting bolts. Push the two 5/16 x 1.5-inch full-thread bolts up through the bottom of the mower deck and screw them into the threaded holes in the small rectangular Support Blocks (Fig. 1). Line the two blocks up parallel with each other and tighten firmly with a wrench. You will now have two threaded studs protruding up from your mower deck. Drop the Boot Plate over the threaded studs and spin on the Boot Plate Clamp Knobs.

### Mounting the Boot

1. Hold the boot snugly against the lower surface of the Boot Plate directly in front of the deck opening (the boot may be moved forward or backward as necessary for installation). Mark the four bolt hole positions with the marker pen (Fig. 2). Loosen the Clamp Knobs and remove the Boot Plate from your mower deck.
2. Place the boot on a stable surface. Using the Boot Plate as a template, drill four 5/16" holes through the boot in the four bolt positions. The best way is to first drill one hole, and then drop a bolt through the hole temporarily to keep the plate lined up. Repeat the process until all holes have been drilled. Remove the bolts.

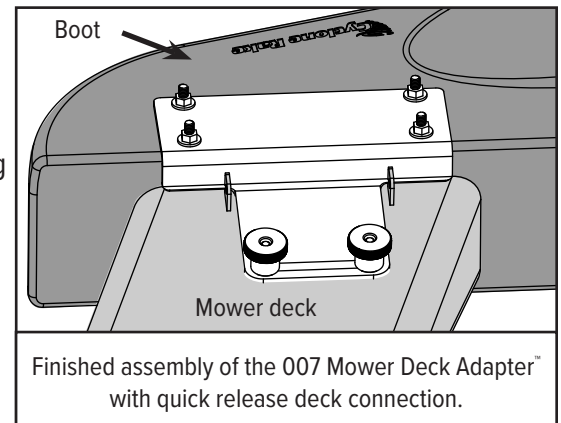
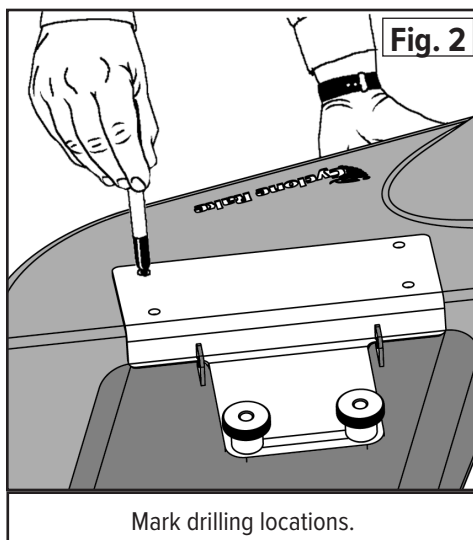

*Continued on Reverse.*

3. Install the 5/16 x 1-inch mounting bolts each with a fender washer and tighten. The bolt heads should be on the inside, to avoid blocking the boot opening (Fig. 3).
4. Install the MDA on the mower deck. Trace around the deck opening with the marker pen (Fig. 4). Then remove the MDA from the mower deck.
5. Drill a starter hole inside the marked area, (Fig. 5) and use an electric jigsaw or keyhole saw to cut the boot to the shape of your deck opening. Place the MDA assembly back onto the deck studs, then place one rubber washer on each stud. Now, spin on the Clamp Knobs and tighten all the bolts.
6. Snap the hose collar onto the MDA with the latches provided. Cut the hose to length as described in your owner's manual.

***That's it you're finished.***

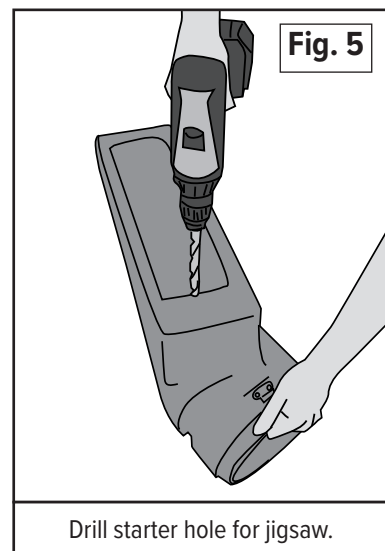
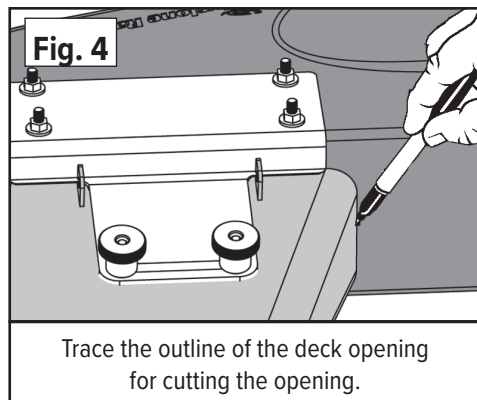
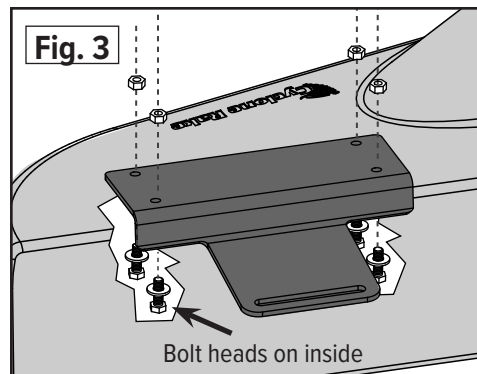

### MDA-007 COMPONENT LIST

PART NO.	NAME	QTY
01-02-143	Standard Boot w/strikes	1
05-02-143	Standard Boot w/strikes - XL	1
06-02-143	Standard Boot w/strikes - Z-10	1
01-01-150	5/16-18 x 1.5 Full-thread bolt	2
01-01-151	5/16-18 Nylon lock nut	4
01-01-152	5/16 Washer - type A series W	2
01-01-171	5/16-18 x 1 Hex bolt	4
01-01-175	Fender washer	4
01-01-291	Clamp Knob - Boot Plate	2
01-01-441	Support Block	2
01-01-829	LB-Boot Plate	1
01-01-1990	Rubber washer	2
01-02-125	Support block, 1.5 bolt & washer	2
01-02-564	Standard strike w/hardware	3
01-02-142	8" x 8" Collar complete - green	1
01-02-486	7" x 8" Collar complete	1
05-02-080	8" x 8" Collar complete - yellow	1
06-02-080	10" x 10" Collar complete	1
08-02-080	8" x 6" Collar complete	1

