

Assembly and Installation

This Mower Deck Adapter (MDA) is designed to work with several mower deck designs. The MDA does not need an airtight fit to deliver exceptional vacuum performance. It simply needs to be installed in front of the opening on the mower deck. Follow the instructions below to install.

Mounting the Boot Plate Bracket & Boot Plate to Your Mower Deck

1. Remove the hinged grass deflector from your mower deck to expose the deck opening. On most machines this is just a matter of removing two bolts.

Safety Note: If you remove the Mower Deck Adapter later, you **MUST** re-install the grass deflector.

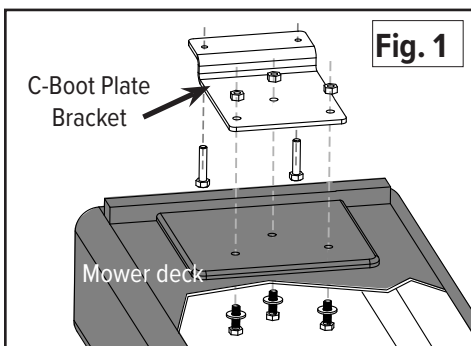

2. Position the C-Boot Plate Bracket over the existing holes in the mower deck. If the holes do not line up, trace the outline of the holes onto the mower deck with a marker pen. Then drill three 5/16" holes for the mounting bolts (Fig. 1).
3. Attach the C-Boot Plate Bracket to the mower deck using the three 5/16 x 1-inch bolts and nuts. Thread the two 5/16 x 1.5-inch full-thread bolts up through the Boot Plate Bracket. Drop the Standard Boot Plate over the full-thread bolts and spin on the Boot Plate Clamp Knobs (Fig. 2).

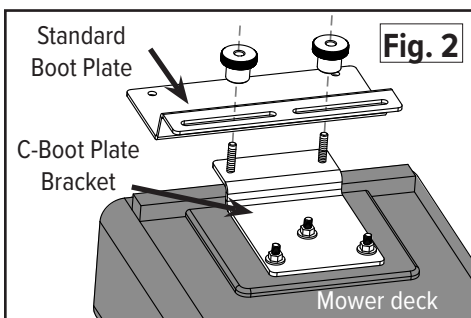

Mounting the Boot

1. First, using a tape measure or ruler, measure the height of your deck opening (Fig. 3). If it is up to 4 1/2-inches, mount the boot plate directly to the boot. If it is over 4 1/2-inches in height, use the "U" shaped Boot Plate Spacers (see Fig. 6 on reverse).

IMPORTANT: The arms of the spacers must face up, against the Boot Plate, to avoid cutting into the boot.

3. Place the boot on a stable surface. Using the Boot Plate as a template, drill four 5/16" holes through the boot in the four bolt positions. The best way is to first drill one hole, and then drop a bolt through the hole temporarily to keep the plate lined up. Repeat the process until all holes have been drilled. Remove the bolts.

Continued on Reverse.

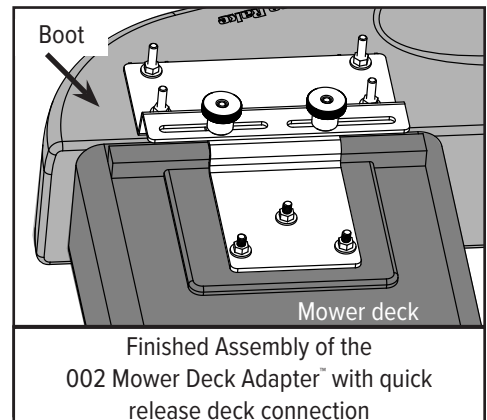
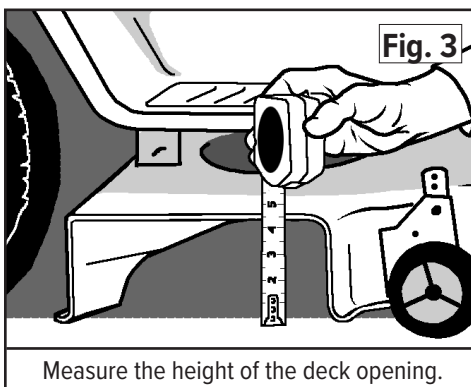

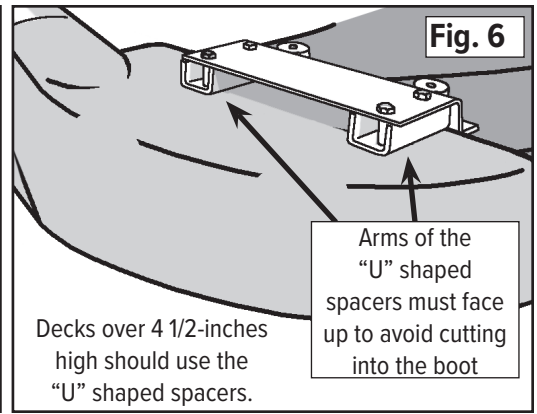
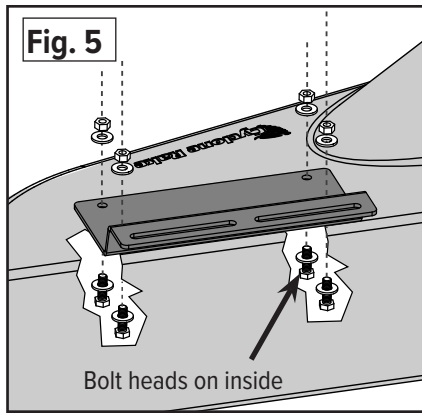
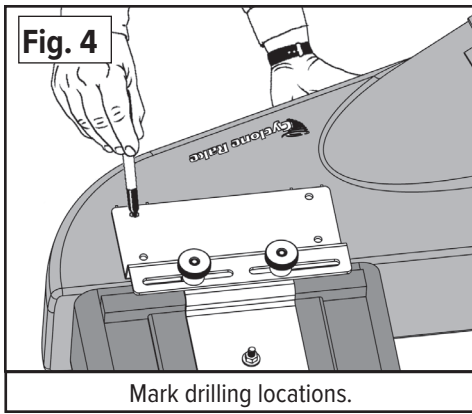

4. Install the mounting bolts and tighten. The bolt heads should be on the inside, to avoid blocking the boot opening (Fig. 5).

NOTE: For decks over 4 1/2-inches high, place the two metal Boot Plate Spacers between the boot and the Boot Plate with the "U" arms facing up (Fig. 6). Install the four 5/16 x 2-inch mounting bolts and tighten. The bolt heads should be on the inside, to avoid blocking the boot opening (Fig. 5).

5. Install the MDA on the mower deck. Trace around the deck opening with the marker pen (Fig. 7). Then remove the boot from the mower deck.

6. Drill a starter hole inside the marked area, (Fig. 8) and use an electric jigsaw or keyhole saw to cut the boot to the shape of your deck opening. Place the MDA assembly back onto the deck studs, then place one rubber washer on each stud. Now, spin on the Clamp Knobs and tighten all the bolts.

7. Attach the hose collar onto the MDA with the latches provided. Cut the hose to length as described in your owner's manual.

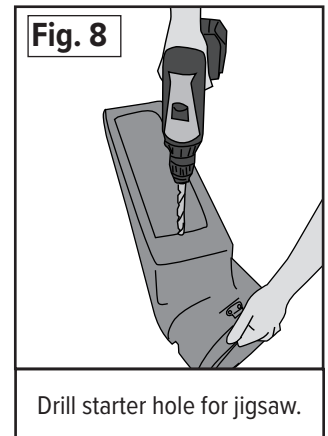
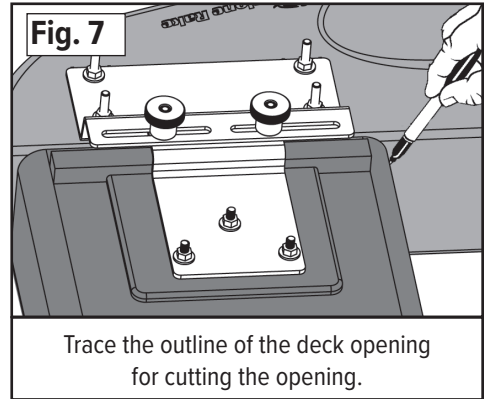

That's it you're finished.

MDA-002 COMPONENT LIST

PART NO.	NAME	QTY
01-02-143	Standard Boot w/strikes	1
05-02-143	Standard Boot w/strikes - XL	1
06-02-143	Standard Boot w/strikes - Z-10	1
01-01-069	Standard Boot Plate	1
01-01-150	5/16-18 x 1.5 Full-thread bolt	2
01-01-151	5/16-18 Nylon lock nut	7
01-01-152	5/16 Washer - type A series W	7
01-01-153	5/16-18 x 2 Hex bolt	4
01-01-171	5/16-18 x 1 Hex bolt	7
01-01-291	Clamp knob - Boot Plate	2
01-01-495	Boot Plate "U" shaped spacer	2
01-01-992	C-Boot Plate Bracket	1
01-01-1990	Rubber washer	2
01-02-564	Standard strike w/hardware	3
01-02-142	8" x 8" Collar complete - green	1
01-02-486	7" x 8" Collar complete	1
05-02-080	8" x 8" Collar complete - yellow	1
06-02-080	10" x 10" Collar complete	1
08-02-080	8" x 6" Collar complete	1

