

Assembly and Installation

This Mower Deck Adapter (MDA) is designed to work with several mower deck designs. The MDA does not need an airtight fit to deliver exceptional vacuum performance. It simply needs to be installed in front of the opening on the mower deck. Follow the instructions below to install.

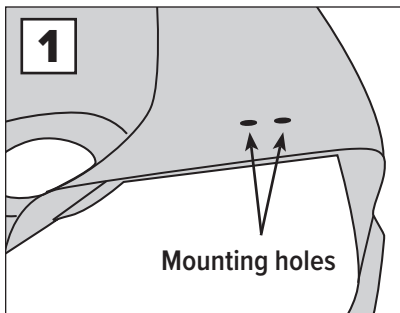

Fig 1. Remove the hinged grass deflector from your mower deck to expose the deck opening and the two mounting holes.

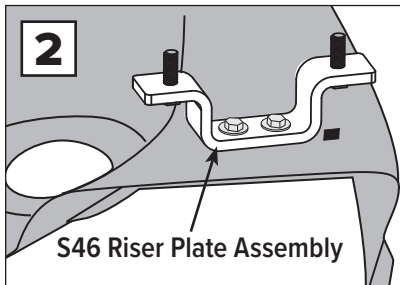

Fig 2. Attach the S46 Riser Plate Assembly to the mower deck using two 5/16 x 1-inch bolts provided. Use four small washers under the nuts and bolts.

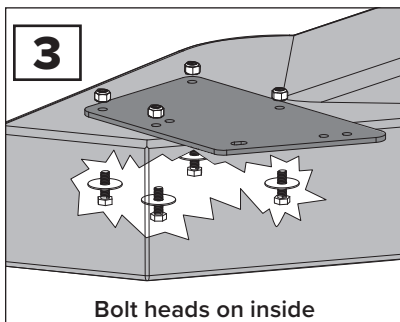

Fig 3. Install the four 5/16 x 1-inch bolts, each with a 5/16 fender washer, up through the inside of the boot and the boot plate. Secure with the 5/16 nylon lock nuts.

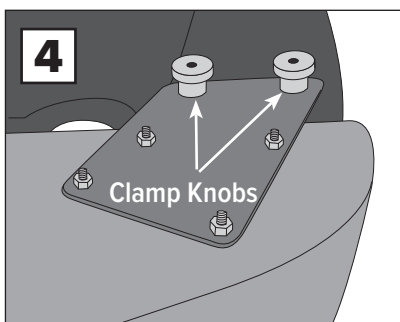

Fig 4. Install the MDA assembly onto the mower deck, Place one rubber washer on each stud. Spin on the Boot Plate Clamp Knobs over the mounting bolts.

Connect the hose collar onto the MDA with the latches and cut the hose to length as described in your owner's manual if needed

That's it you're finished!

SAFETY NOTE:
If you remove the Mower Deck Adapter later, you MUST re-install the grass deflector.

MDA-001 COMPONENT LIST

PART NO.	NAME	QTY
01-02-1145	K Boot w/strikes	1
05-02-1145	K Boot w/strikes - XL	1
06-02-1145	K Boot w/strikes - Z-10	1
01-01-151	5/16-18 Nylon lock nut	6
01-01-152	5/16 Washer	4
01-01-171	5/16-18 x 1 Bolt	6
01-01-175	5/16 Fender washer	4
01-01-291	Clamp Knob - Boot Plate	2
01-02-478	S46 Riser Plate Assembly	1
01-01-809	Special Boot Plate	1
01-01-1990	Rubber washer	2
01-02-564	Standard strike w/hardware	3
01-02-142	8" x 8" Collar complete - green	1
01-02-486	7" x 8" Collar complete	1
05-02-080	8" x 8" Collar complete - yellow	1
06-02-080	10" x 10" Collar complete	1
08-02-080	8" x 6" Collar complete	1

