

## Installation Instructions

The Cyclone Rake 208Z Special Hitch is designed to fit multiple mower types. To install the hitch, follow the instructions below.

1. Place the mower on a flat level surface, such as a concrete floor.
2. The 208Z Special Hitch attaches to the rear hitch bracket (A) (Fig. 1).
3. Place the 208Z hitch (1) over the hitch bracket with the channel supports on the underside of the hitch. Align the center bolt hole with the hole in the rear hitch bracket. (See exploded view below.)
4. Secure the hitch by placing the 5/8 x 2.0 inch hex bolt (2) through the hitch. Place the lock washer (4) over the bolt and fasten with 5/8 lock nut. Tighten the bolt firmly.

That's it. Your 208Z Special Hitch installation is complete.

*To finish the assembly of your Cyclone Rake, please return to your Owner's Manual now.*

**Note:** Check the bolts before each use to make sure everything is tight.

**User Tip:** A small amount of grease on the Cyclone Rake hitch pins will help minimize hitch bar wear over time.

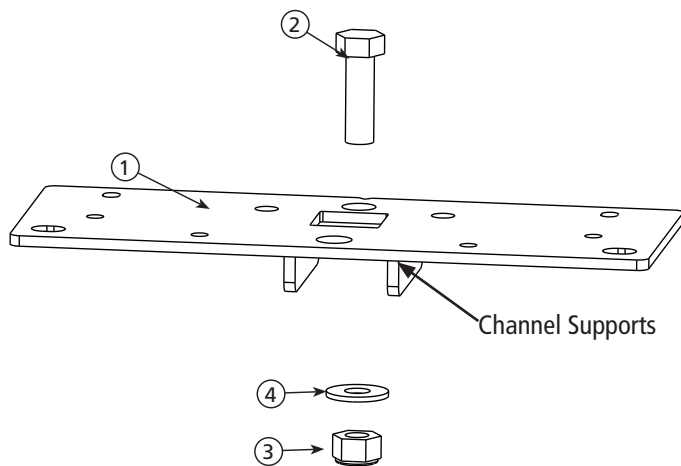
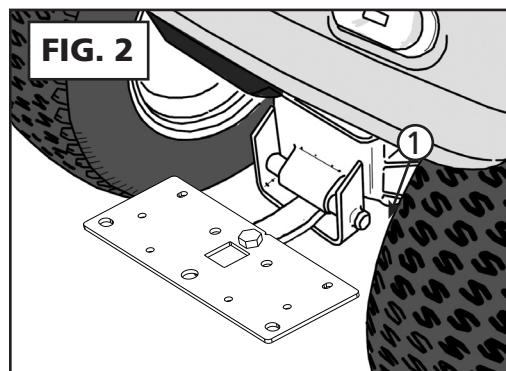
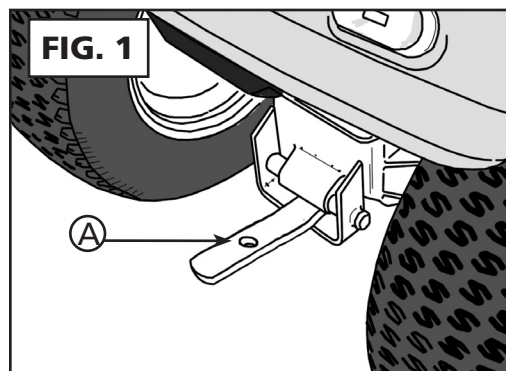

### 208Z Special Hitch COMPONENT LIST

KEY#	PART #.	NAME	QTY
1	01-02-576	208Z Special Hitch	1
2	01-01-1041	5/8-11 x 2.0 Hex bolt	1
3	01-01-824	5/8-11 Lock nut	1
4	01-01-1121	5/8 Washer	1