

Installation Instructions

The Cyclone Rake 208Y Special Hitch is designed to fit multiple mower types. To install the hitch, follow the instructions below.

1. Place the mower on a flat level surface such as a concrete floor.
2. Remove the hitch tang (A) from the mower (Fig. 1).
Save the bolts; you will need them to install the 208Y Hitch.
3. Position the 208Y Hitch (1) with the two center holes (B) aligned with the mounting holes in the mower frame. Replace the two bolts you just removed.
- 4 Install the two 3/8 x 10 inch bolts (2) through the hitch and through the ears on the side of the transmission case (Fig. 2). Secure these bolts with washers (3) and lock nuts (4). Tighten the nuts so there is just a little tension in the bolts. **DO NOT OVERTIGHTEN** the 10 inch bolts!
5. Tighten bolts (B).

That's it. Your 208Y Special Hitch installation is complete.

To finish the assembly of your Cyclone Rake, please return to your Owner's Manual now.

Note: Check the bolts before each use to make sure everything is tight.

User Tip: A small amount of grease on the Cyclone Rake hitch pins will help minimize hitch bar wear over time.

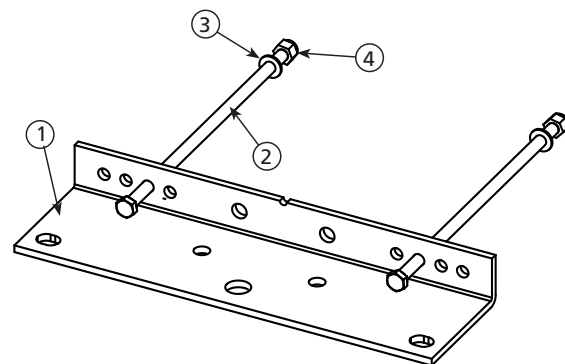
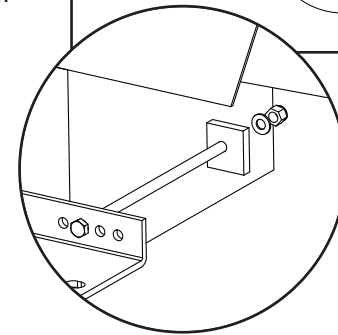
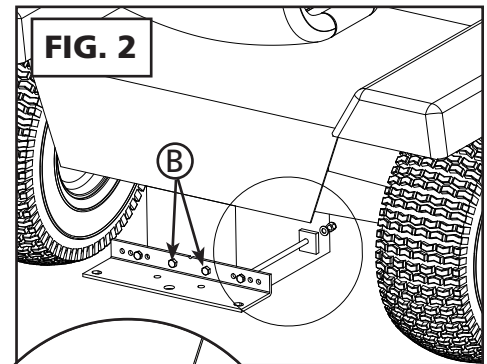
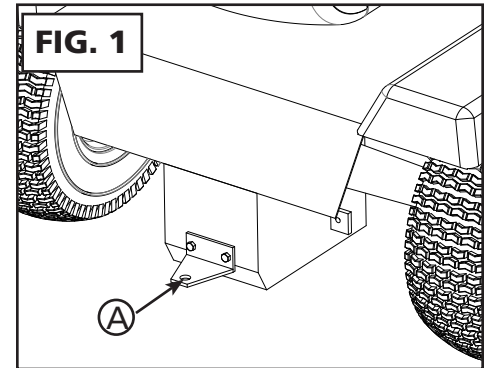

208Y Special Hitch COMPONENT LIST

Key #	PART #	NAME	QTY
1	01-01-099	208Y Special Hitch	1
2	01-01-857	3/8-16 x 10 Hex bolt	2
3	01-01-180	3/8 Washer	2
4	01-01-240	3/8-16 x Lock nut	2