

Installation Instructions

The Cyclone Rake 208V Special Hitch is designed to fit multiple mower types. To install the hitch, follow the instructions below.

1. The 208V Special Hitch (1) attaches to the underside of the rear weight supports (A), (Fig. 1).
2. Using the 3/8-16 x 3 full thread bolts (2), 3/8 washers (4), hitch bar washers (3) and lock nuts (5), attach the 208V hitch as shown in Fig 2.

That's it. Your 208V Special Hitch installation is complete.
To finish the assembly of your Cyclone Rake, please return to your Owner's Manual now.

Note: Check the bolts before each use to make sure everything is tight.

User Tip: A small amount of grease on the Cyclone Rake hitch pins will help minimize hitch bar wear over time.

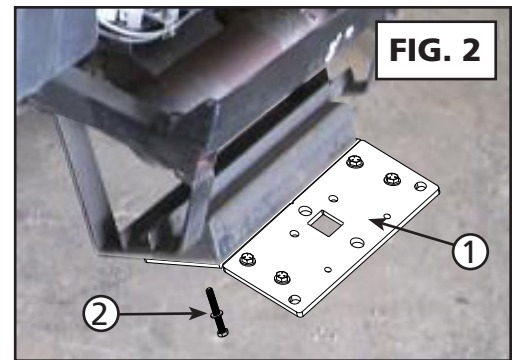
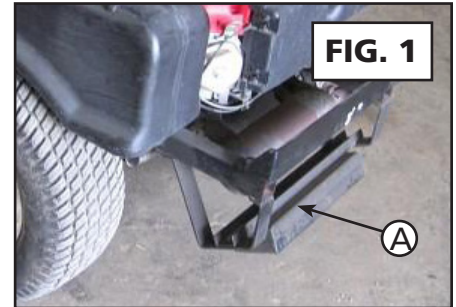

208V Special Hitch COMPONENT LIST

KEY #	PART #	NAME	QTY
1	01-01-1810	Flat Hitch Bar	1
2	01-01-1103	208V Special Hitch Leg	2
3	01-01-1724	3/8-16 x 3 Full thread bolt	2
4	01-01-1434	Hitch bar washer	2
5	01-01-180	3/8 Washer	10
6	01-01-240	3/8-16 Lock nut	6
7	01-01-410	3/8-16 x 1.5 Hex Bolt	4

