

## Installation Instructions

The Cyclone Rake 208G Special Hitch is designed to fit multiple mower types. To install the hitch, follow the instructions below.

1. Place the mower on a flat level surface, such as a concrete floor.
2. The 208G Special Hitch should be installed horizontally, and attached to the mower's rear bracket (A), (Fig. 1).
3. Begin by removing the four bolts (B) that secure the mower hitch tang to the rear bracket.
4. Place the first 208G Special Hitch Bracket (1) over the two holes on the left side and secure with two 3/8 x 1.5 inch hex bolts (2), washers (3) and lock nuts (4).
5. Repeat for the second bracket (1) on the right side. (Fig. 2).
6. Tighten the hitch bar bolts.

That's it. Your 208G Special Hitch installation is complete. *To finish the assembly of your Cyclone Rake, please return to your Owner's Manual now.*

**Note:** Check the bolts before each use to make sure everything is tight.

**User Tip:** A small amount of grease on the Cyclone Rake hitch pins will help minimize hitch bar wear over time.

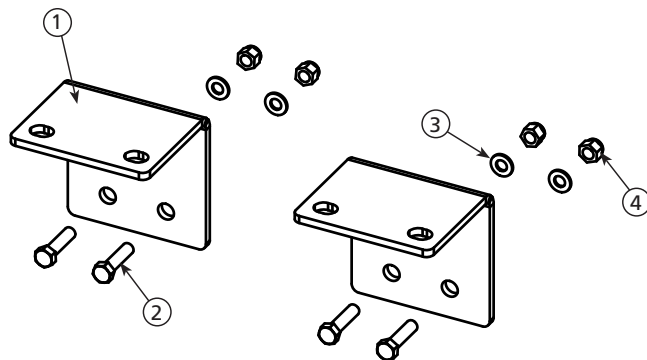
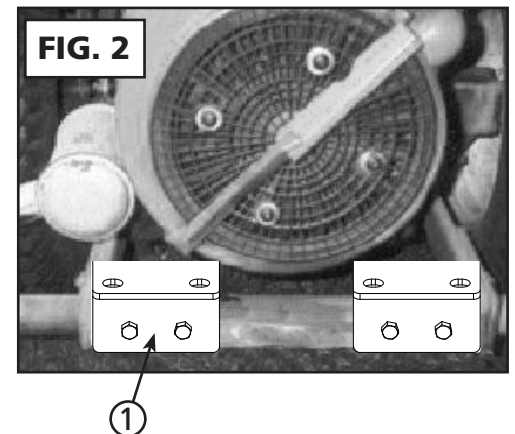
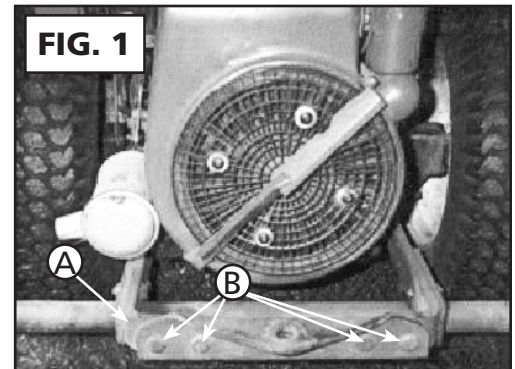

### 208G Special Hitch COMPONENT LIST

KEY #	PART #	NAME	QTY
1	01-01-315	208G Special Hitch Bracket	2
2	01-01-410	3/8-16 x 1.5 Hex bolt	4
4	01-01-180	3/8 Washer	4
3	01-01-240	3/8-16 Lock nut	4