

Installation Instructions

The Cyclone Rake 208F Special Hitch is designed to fit multiple mower types. To install the hitch, follow the instructions below.

1. Place the mower on a flat level surface, such as a concrete floor.
2. The 208F Special Hitch attaches to the rear wheel bracket (A), (Fig. 1).
3. Place the 208F hitch (1) over the bracket with the channel supports on the underside of the hitch. Align the center bolt hole with the hole in the rear wheel bracket. (See exploded view below.)
4. Secure the hitch by placing the 3/4 x 1.75-inch hex bolt (2) through the hitch. Fasten with the 3/4 nylon lock nut (3) provided.
5. Tighten the nut firmly.

That's it. Your 208F Special Hitch installation is complete.

To finish the assembly of your Cyclone Rake, please return to your Owner's Manual now.

Note: Check the hitch bolt before each use to make sure everything is tight.

User Tip: A small amount of grease on the Cyclone Rake hitch pins will help minimize hitch bar wear over time.

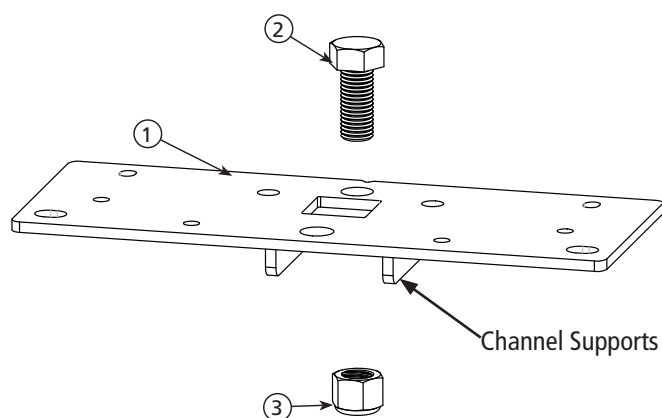
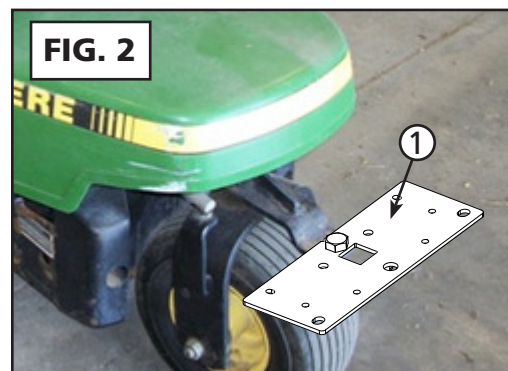
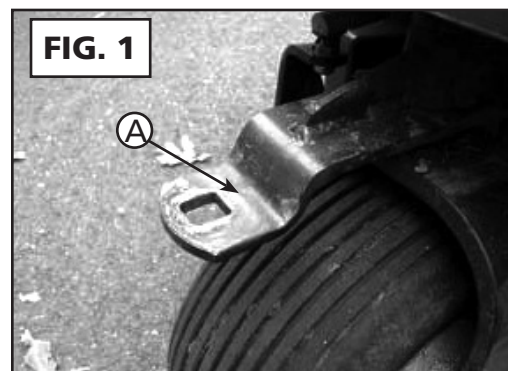

208F Special Hitch COMPONENT LIST

KEY#	PART #.	NAME	QTY
1	01-02-572	208F Special Hitch	1
2	01-01-1828	3/4-10 x 1.75 Hex bolt	1
3	01-01-1829	3/4-10 Nylon lock nut	1