

## Installation Instructions

The Cyclone Rake 208C Special Hitch is designed to fit multiple mower types. To install the hitch, follow the instructions below.

1. Place the mower on a flat level surface such as a concrete floor.
2. If your mower has an existing hitch tang (A), begin by removing it from the back of your mower. See Figure 1.
3. Position the 208C Hitch over the holes left by removing the hitch tang.

**Note:** There are several different hole patterns, depending on your specific mower. Use the holes that match.

4. Secure the 208C Hitch to the mower using the three 3/8 bolts (2), washers (4) and lock nuts (3) provided. See Figure 2.

5. Tighten all bolts.

That's it. Your 208C Special Hitch installation is complete.

**To finish the assembly of your Cyclone Rake, please return to your Owner's Manual now.**

**Note:** Check the bolts before each use to make sure everything is tight.

**User Tip:** A small amount of grease on the Cyclone Rake hitch pins will help minimize hitch bar wear over time.

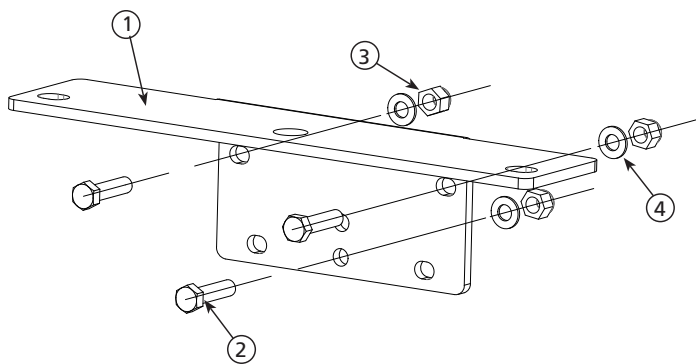
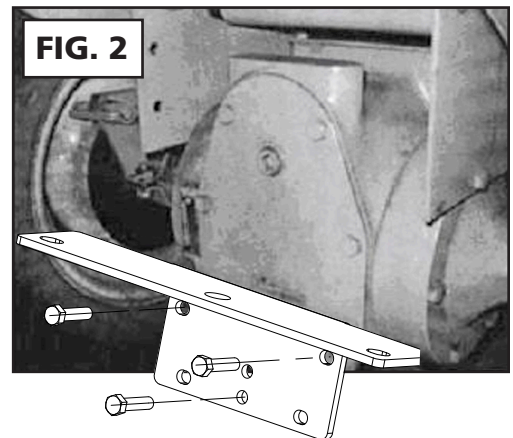
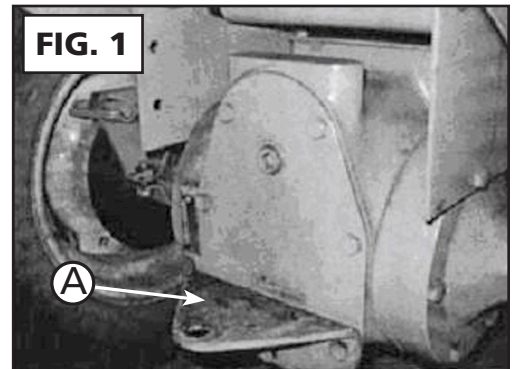

### 208C Special Hitch COMPONENT LIST

KEY #	PART #	NAME	QTY
1	01-01-1438	208C Special Hitch	1
2	01-01-410	3/8-16 x 1.5 Hex bolt	3
3	01-01-240	3/8-16 Lock nut	3
4	01-01-180	3/8 Washer	3