

Installation Instructions

The Cyclone Rake 208-018 Special Hitch is designed to fit multiple mower types. To install the hitch, follow the instructions below.

- (Fig. 1)** Remove the two bolts (A) and nuts from the rear plate of the mower. **NOTE:** the red backing plate will become dislodged, but will be replaced when the hitch is assembled.
- (Fig. 2)** Place the G160 Weldment onto the rear of the mower and drop in two new 3/8-16 bolts (B) through the hitch and the holes in the rear of the mower.
- (Fig. 2)** While holding the weldment in place up against the rear of the mower, mark the location of the lower bracket holes (C) onto the tractor using a marker pen.
- Remove the G160 weldment, use a center punch to mark the hole locations. Drill the holes first using a 1/4" drill bit. Then follow up with a 3/8" drill.
- (Fig. 3)** Place the G160 Weldment back onto the tractor and install the 3/8-16 mounting bolts (B), replace the red backing plate then install hitch bar washers and lock nuts in the upper hole locations and tighten firmly.
- (Fig. 4)** Install the remaining 3/8-16 x 1.5 bolts, hitch bar washers, and lock nuts into the lower hole locations and tighten firmly.

That's it. Your 208-018 Special Hitch installation is complete. *To finish the assembly of your Cyclone Rake, please return to your Owner's Manual now.*

Note: Check the bolts before each use to make sure everything is tight.

User Tip: A small amount of grease on the Cyclone Rake hitch pins will help minimize hitch bar wear over time.

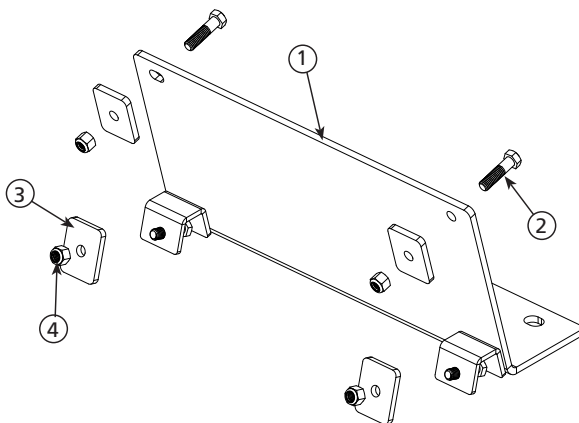
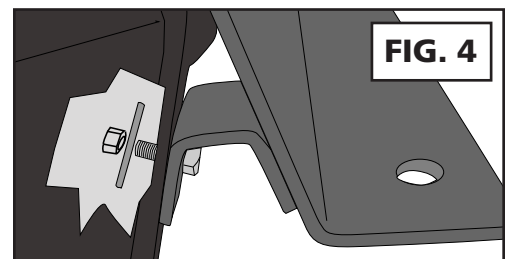
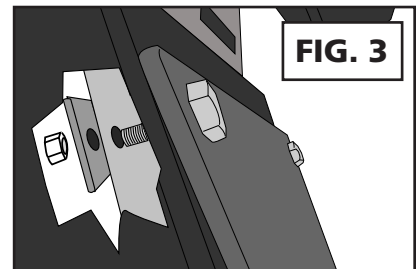
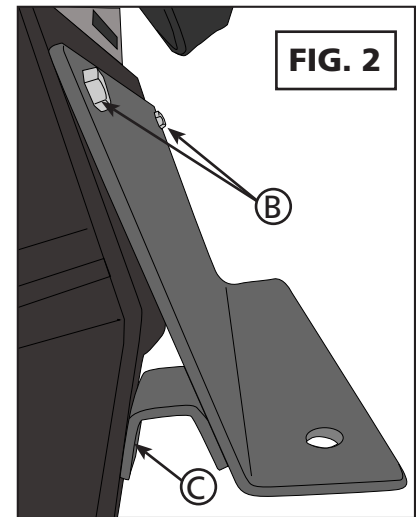
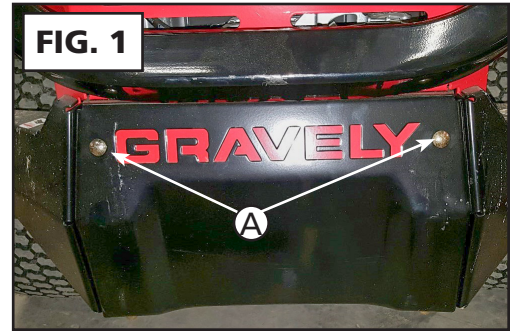

208-018 Special Hitch COMPONENT LIST

KEY #	PART #	NAME	QTY
1	01-02-677	G160 Weldment	1
2	01-01-410	3/8-16 x 1.5 Hex bolt	4
3	01-01-1434	Square Washer	4
4	01-01-240	3/8-16 Lock nut	4