

Installation Instructions

The Cyclone Rake 208-009 Special Hitch is designed to fit multiple mower types. To install the hitch, follow the instructions below.

1. Place the mower on a flat level surface, such as a concrete floor.
2. The 208-009 Special Hitch attaches to the top of the rear frame on your mower as shown in Figure 1.
3. Remove existing bolts and hardware from rear tractor frame (A).
4. Assemble the 208-009 Special Hitch. Secure each Grasshopper hitch leg (2) to the 90° hitch bar (1) using two 3/8 x 1.5-inch bolts, washers and lock nuts as shown in Figure 2.
5. Install the assembled 208-009 Special Hitch using the remaining two 3/8 x 1.5-inch bolts, washers and lock nuts, provided. The bolt heads and washers should be installed on top of the hitch as shown in Figure 3.

That's it. Your 208-009 Special Hitch installation is complete.

To finish the assembly of your Cyclone Rake, please return to your Owner's Manual now.

Note: Check the bolts before each use to make sure everything is tight.

User Tip: A small amount of grease on the Cyclone Rake hitch pins will help minimize hitch bar wear over time.

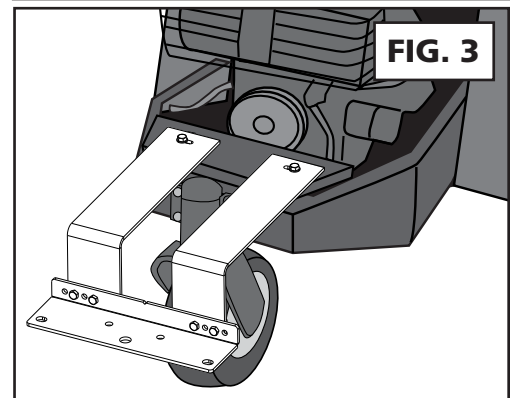
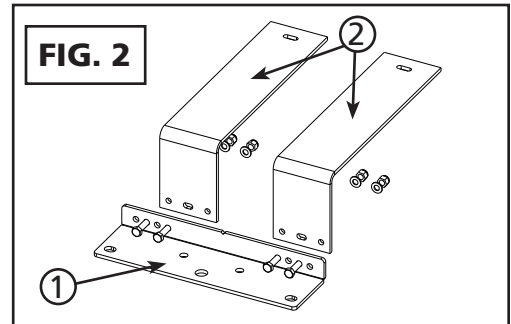
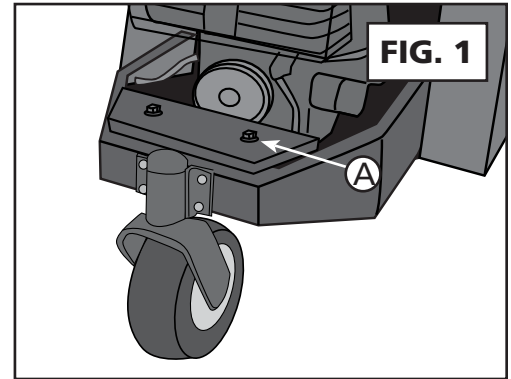

208-009 Special Hitch COMPONENT LIST

KEY #	PART #	NAME	QTY
1	01-01-870	90° Hitch bar	1
2	01-01-1780	Grasshopper hitch leg	2
3	01-01-410	3/8-16 x 1.5 Hex bolt	6
4	01-01-180	3/8 Washer	6
5	01-01-240	3/8-16 Lock nut	6

