

Installation Instructions

The Cyclone Rake 208-008 Special Hitch is designed to fit multiple mower types. To install the hitch, follow the instructions below.



1. Place the mower on a flat, level surface, such as a concrete floor.
2. **(Fig. 2)** The 208-008 Special Hitch Bar should be installed horizontally, centered between your mower wheels. The ideal height of the hitch bar is approximately 12 inches from the ground.

Note: The hitch bar can be installed anywhere from 10 to 14 inches from the ground if you need to clear any other hardware or mower attachments.

3. Locate and mark the center between your mower's rear wheels using a measuring tape. Draw a vertical line at the center using a marker pen.
4. The hitch bar has a "V" notch at the center as a guide for aligning it with the center line that you marked. Place the lower lip of the hitch bar approximately 12 inches from the ground and prepare to mark the position of the hitch bar on the mower.
5. Choose a pair of bolt holes that are about one inch from the edge of the mower's rear plate. You want the holes as wide as possible, but still have enough room for bolts and washers on the inside. Mark the hole locations with a marker pen.
6. Before drilling, check behind the mower plate to be sure there are no obstacles. If there are, choose a slightly different height for the hitch bar, or a different pair of holes that can be used without interference.

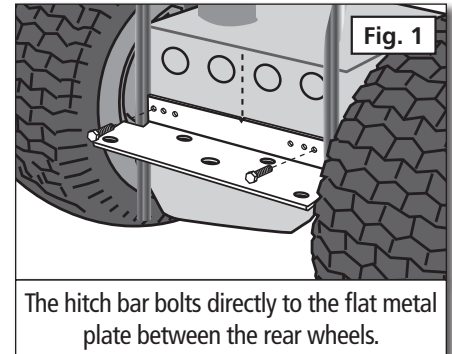

7. **(Fig. 3)** Drill one hole first. Use a center punch and hammer to make a sharp dent at the location of the first hole. This keeps the drill from "walking." Drill through first with a 1/4" drill bit. Then follow with a 3/8" drill bit. Use firm pressure and low speed. A little oil on the drill bit also helps.

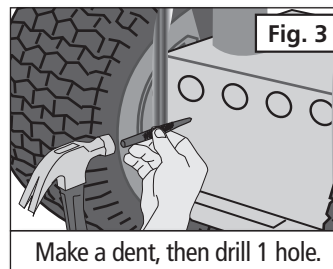

8. **(Fig. 4)** Install one 3/8" bolt, hitch bar washer and lock nut. Install the bolt with the bolt head facing out. The hitch bar washer is installed on the inside of the mower plate. Secure with the nylon lock nut provided. Tighten moderately. If there are protrusions or obstacles on your mower's rear plate, space the hitch bar out with washers.

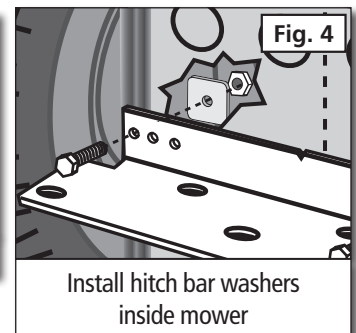
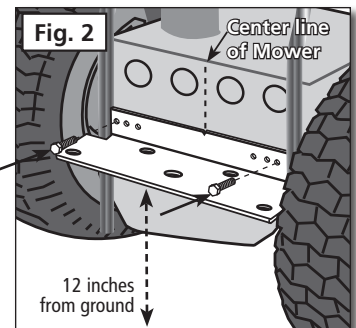

9. **(Fig. 5)** With the first bolt installed, hold the hitch bar level and drill the second hole, by placing the 3/8" drill bit directly through the hitch bar while drilling. Using the hitch bar as a guide this way will ensure your two holes will line up correctly.
10. Install the second 3/8" bolt, hitch bar washer and nylon lock nut. Tighten both bolts firmly.

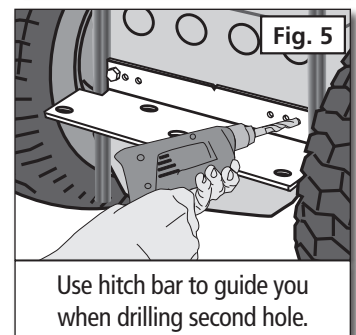

That's it. Your hitch bar assembly is complete.

Component list on back.

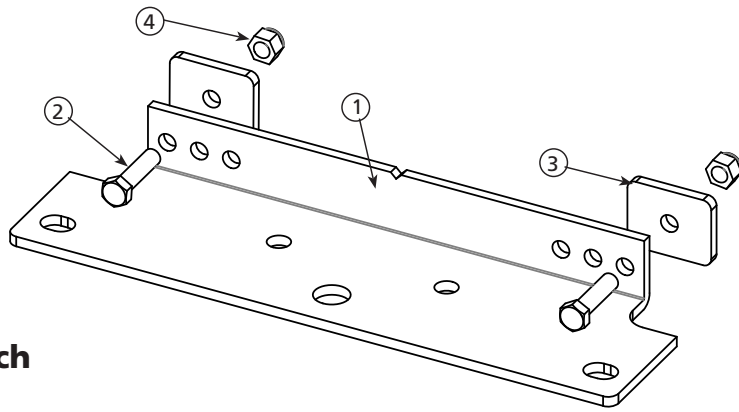

208-008 Special Hitch
 COMPONENT LIST

| KEY # | PART # | NAME | QTY |
|-------|------------|-----------------------|-----|
| 1 | 01-01-1741 | 208-008 Special Hitch | 1 |
| 2 | 01-01-410 | 3/8-16 x 1.5 Hex bolt | 2 |
| 3 | 01-01-1434 | Hitch bar washer | 2 |
| 4 | 01-01-240 | 3/8-16 Nylon lock nut | 2 |