

Installation Instructions

The Cyclone Rake 208-021 Special Hitch is designed to fit multiple mower types. To install the hitch, follow the instructions below.

1. Place the mower on a flat level surface, such as a concrete floor.
2. Starting on either side of the mower, remove the three or four bolts (A) holding the engine guard to the frame of the mower. (Fig 1)
3. Attach and secure one of the side weldments (B) using the three or four 5/16" x 1.0 inch bolts and 5/16" lock nuts provided. (fig 2)

Repeat this process on the other side of the mower.

4. Attach the rear plate (C) to each end of the side weldment using the 5/16" x 1 inch bolts and secure with the 5/16" lock nuts provided. (Fig 3)

NOTE: Remove mower's single point hitch (H) if it's in the way of rear plate (C). The center hole of the provided 90° hitch bar (D) could be used.

5. Attach the 90° hitch bar (D) to the rear plate using the 3/8 x 1.5 inch bolts, hitch bar washers, and nylon lock nuts provided and tighten securely. (Fig 4)

That's it. Your 208-021 Special Hitch installation is complete.

To finish the assembly of your Cyclone Rake, please return to your Owner's Manual now.

Note: Check the bolts before each use to make sure everything is tight.

USER TIP: A small amount of grease on the Cyclone Rake hitch pins will help minimize hitch bar wear over time.

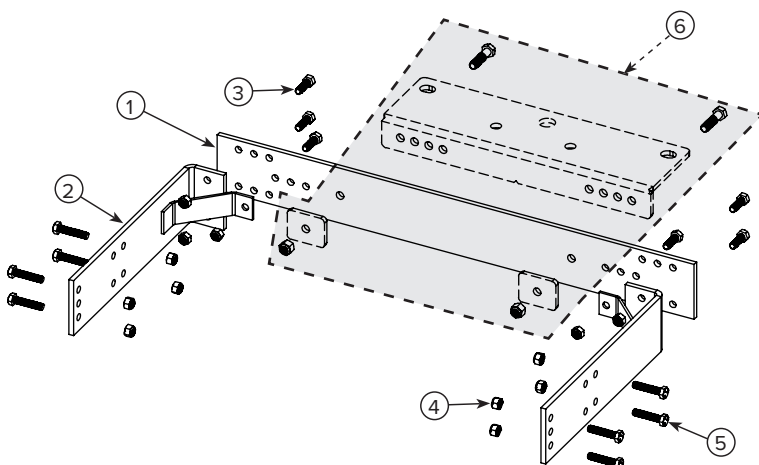
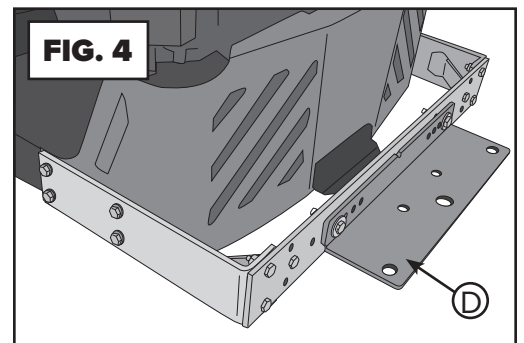
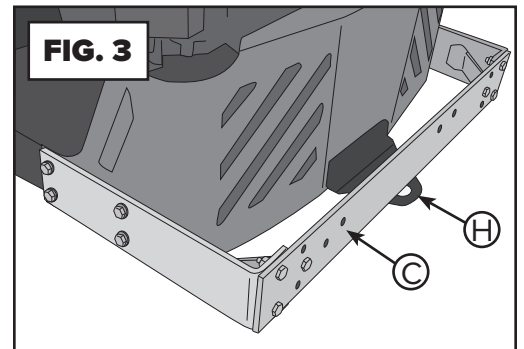
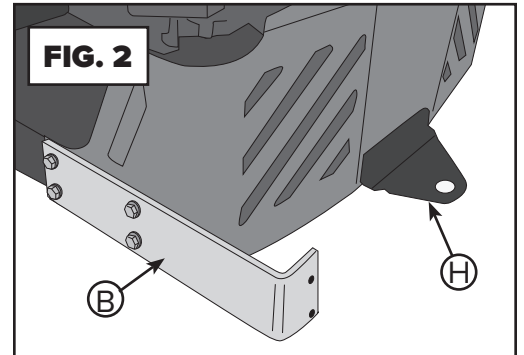
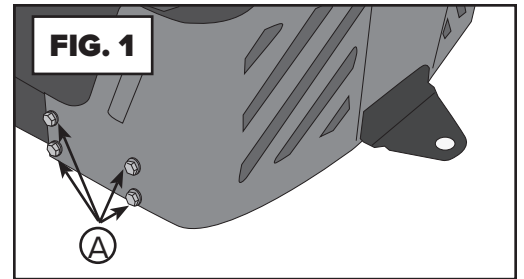

208-021 Special Hitch COMPONENT LIST

KEY#	PART #.	NAME	QTY
1	01-01-2211	208-021 Hitch Rear Plate	1
2	01-02-2210	208-021 Hitch Side Weldment	2
3	01-01-171	5/16-18 x 1.0 Hex bolt	6
4	01-01-151	5/16-18 Nylon lock nut	14
5	01-01-171	5/16-18 x 1.0 hex bolt	8
6	01-02-107	90° Hitch Bar with hardware	1