

Installation Instructions

The 208-016 Hitch Bar is bolted horizontally to the rear of your mower. The Cyclone Rake® uses two hitch pins which drop into holes in the ends of the hitch bar. Once installed, the hitch bar can be left on year-round. To install the hitch bar on a mower with square tubing in the rear, follow the instructions below. If you are attaching to a John Deere with the John Deere rear bumper accessory, follow the instructions on the following page.

1. Place the mower on a flat, level surface, such as a concrete floor.
2. **(Fig. 1)** The 208-016 hitch bar should be installed horizontally onto the center of the mower's rear lower frame. The ideal height of the hitch bar is approximately 12 inches from the ground.

Note: The hitch bar can be installed anywhere from 10 to 14 inches from the ground if you need to clear any other hardware or mower attachments.

3. Locate and mark the center between the bars using a measuring tape. Draw a vertical line at the center using a marker pen.
4. The hitch bar has a "V" notch at the center as a guide for aligning it with the center line that you marked. Place the lower lip of the hitch bar approximately 12 inches from the ground.
5. Choose a pair of bolt holes in the hitch bar. You want the holes as wide as possible, but still have enough room for hitch bar washers on the inside. Mark the hole locations with the marker pen.
6. Before drilling, check to be sure there are no obstacles. If there are, choose a slightly different pair of holes that can be used without interference.
7. **(Fig. 2)** Drill one hole first. Use a center punch and hammer to make a sharp dent at the location of the first hole. This keeps the drill from "walking." Drill through first with a 1/4" drill bit. Then follow with a 3/8" drill bit. Use firm pressure and low speed. A little oil on the drill bit also helps.
8. **(Fig. 3)** Install one 3/8 x 3.5-inch bolt, hitch bar washer and lock nut. Tighten moderately. Install the bolt with the head facing out. The hitch bar washer is installed behind the mower frame. Secure with the nylon lock nut. If there are protrusions or obstacles on your mower's rear frame, space the hitch bar out with washers.
9. **(Fig. 4)** With the first bolt installed, hold the hitch bar level and drill the second hole, by placing the 3/8" drill bit directly through the hitch bar while drilling. Using the hitch bar as a guide this way will ensure your two holes will line up correctly.
10. Install the second 3/8 x 3.5-inch bolt, hitch bar washer and nylon lock nut. Tighten both bolts firmly.

That's it. Your hitch bar assembly is complete.

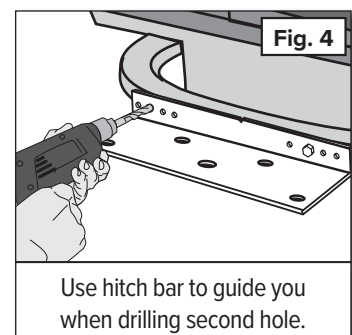
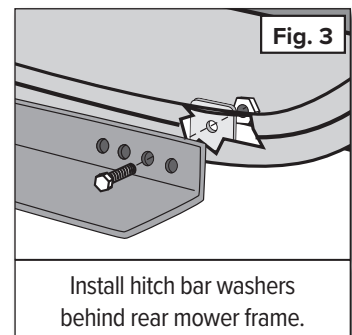
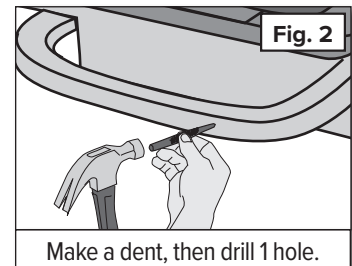
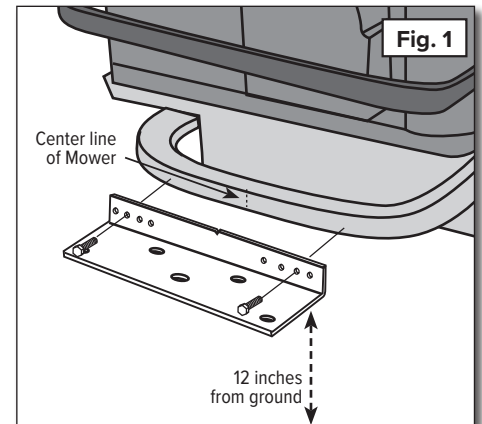

016 Hitch Installation for John Deere rear bumper accessory,

1. Place the mower on a flat level surface, such as a concrete floor.
2. Remove the two m8 x 20 bolts and nuts from the rear of the bumper. (Fig. 1)
3. Bolt the 90° hitch bar to the rear of the tubular bumper and using the two 3/8 x 3.5" bolts and nuts provided. (Fig. 2)

That's it. Your 208-016 Special Hitch installation is complete.

To finish the assembly of your Cyclone Rake, please return to your Owner's Manual now.

Note: Check the bolts before each use to make sure everything is tight.

User Tip: A small amount of grease on the Cyclone Rake hitch pins will help minimize hitch bar wear over time.

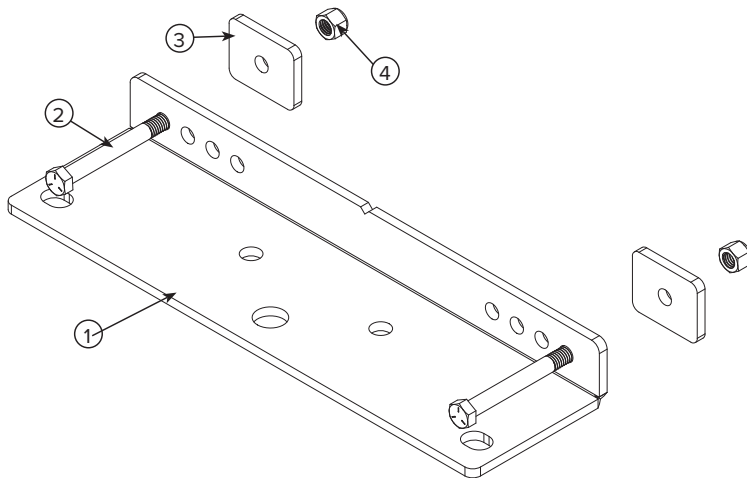

208-016 Special Hitch COMPONENT LIST

KEY#	PART #.	NAME	QTY
1	01-01-870	90° Hitch Bar	1
2	01-01-088	3/8-16 x 3.5 Hex bolt	2
3	01-01-1434	Square washer	2
4	01-01-240	3/8-16 Nylon lock nut	2